

Double Wall Hot Cups

Now
Available in
5 Sizes!



Stanpac manufactures 8oz, 12oz, 16oz, 20oz and 24oz double wall hot cups. These are available in either plain white or custom Flexo printed designs or premium litho designs up to 6 colors. Both the base and the over wrap can be printed. Print quantities can be as low as 15,000 cups with a lead time of 6 weeks for printed cups from approved art. Plain cups are in stock and available for immediate delivery.

Stanpac double wall cups are 20% cooler to the touch compared to our single wall cups. In lab tests, the temperature of a liquid was 12% warmer in our double wall cups compared to single wall cups after 60 minutes.

For more than 75 years, Stanpac has been manufacturing packaging for companies located throughout the United States, Canada and many locations worldwide. We pride ourselves on an unmatched level of customer service, fair pricing, lead times that work for the customer, customized service for unique needs, reasonable minimum run quantities, and on time delivery.

STANPAC

PACKAGING PERFECTION FOR OVER 75 YEARS

DOUBLE WALL THERMAL HOT CUPS

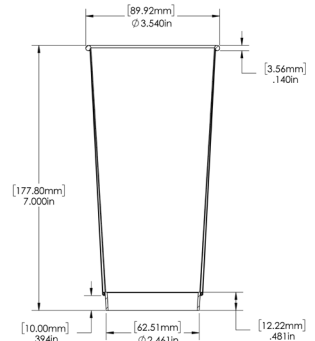
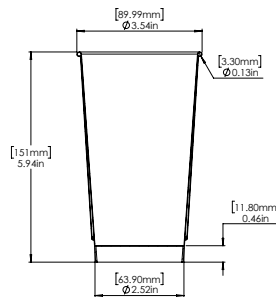
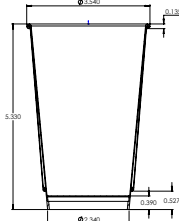
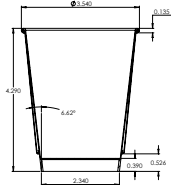
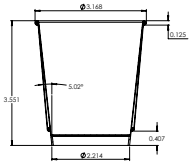

8 OZ

CUP PROPERTIES

Maximum Fill Volume:
9.66 oz / 286 ml
Practical Volume:
8 oz / 237 ml
Stack Height:
18.3" / 25 Cups
Caliper: 15 PT
Poly Configuration: 3/4 mil
Thermal Wrap: 15 PT
Thermal Wrap Poly
Configuration: 3/4 mil

PACKAGING CONFIGURATIONS

8 oz Cups:
Qty per carton: 500
Qty per skid: 15,000
Lbs per carton: 20
Qty per layer: 5
Layer per skid: 6
Carton per skid: 30
Lbs per skid: 635
Box Dimensions:
17" x 14" x 24"
Skid Height: 85"

12 OZ

CUP PROPERTIES

Maximum Fill Volume:
13.85 oz / 410 ml
Practical Volume:
12 oz / 355 ml
Stack Height:
23.4" / 25 Cups
Caliper: 17.5 PT
Poly Configuration: 3/4 mil
Thermal Wrap: 15 PT
Thermal Wrap Poly
Configuration: 3/4 mil

PACKAGING CONFIGURATIONS

12 oz Cups:
Qty per carton: 500
Qty per skid: 12,000
Lbs per carton: 30
Qty per layer: 4
Layer per skid: 6
Carton per skid: 24
Lbs per skid: 755
Box Dimensions:
15" x 18" x 25"
Skid Height: 95"

16 OZ

CUP PROPERTIES

Maximum Fill Volume:
17.4 oz / 515 ml
Practical Volume:
16 oz / 473 ml
Stack Height:
24.4" / 20 Cups
Caliper: 17.5 PT
Poly Configuration: 3/4 mil
Thermal Wrap: 15 PT
Thermal Wrap Poly
Configuration: 3/4 mil

PACKAGING CONFIGURATIONS

16 oz Cups:
Qty per carton: 500
Qty per skid: 10,000
Lbs per carton: 35
Qty per layer: 4
Layer per skid: 5
Carton per skid: 20
Lbs per skid: 725
Box Dimensions:
18" x 18" x 25"
Skid Height: 95"

20 OZ

CUP PROPERTIES

Maximum Fill Volume:
20.25 oz / 599 ml
Practical Volume:
20 oz / 591 ml
Stack Height:
24.0" / 16 Cups
Caliper: 17.5 PT
Poly Configuration: 3/4 mil
Thermal Wrap: 13.5 PT
Thermal Wrap Poly
Configuration: 3/4 mil

PACKAGING CONFIGURATIONS

20 oz Cups:
Qty per carton: 400
Qty per skid: 8,000
Lbs per carton: 26
Qty per layer: 4
Layer per skid: 5
Carton per skid: 20
Lbs per skid: 555
Box Dimensions:
18" x 18" x 25"
Skid Height: 98"

24 OZ

CUP PROPERTIES

Max Fill Volume:
23.6oz / 697.9 ml
Practical Volume:
23oz / 680.2 ml
Stack Height:
24.0" / 14 Cups
Caliper: 17.5 PT
Poly Configuration: 3/4 mil
Thermal Wrap: 13.5 PT
Thermal Wrap Poly
Configuration: 3/4 mil

PACKAGING CONFIGURATIONS

24 oz Cups:
Qty per carton: 350
Qty per skid: 7000
Lbs per carton: 28
Qty per layer: 4
Layer per skid: 5
Carton per skid: 20
Lbs per skid: 620
Box Dimensions:
18"x18"x25"
Skid Height: 98"

Check out our complete line up of products at stanpacnet.com

STANPAC

SMITHVILLE, ONTARIO · BRENHAM, TEXAS · TOTOWA, NEW JERSEY · QUERETARO, MEXICO

STANPACNET.COM | 905 957 3326