

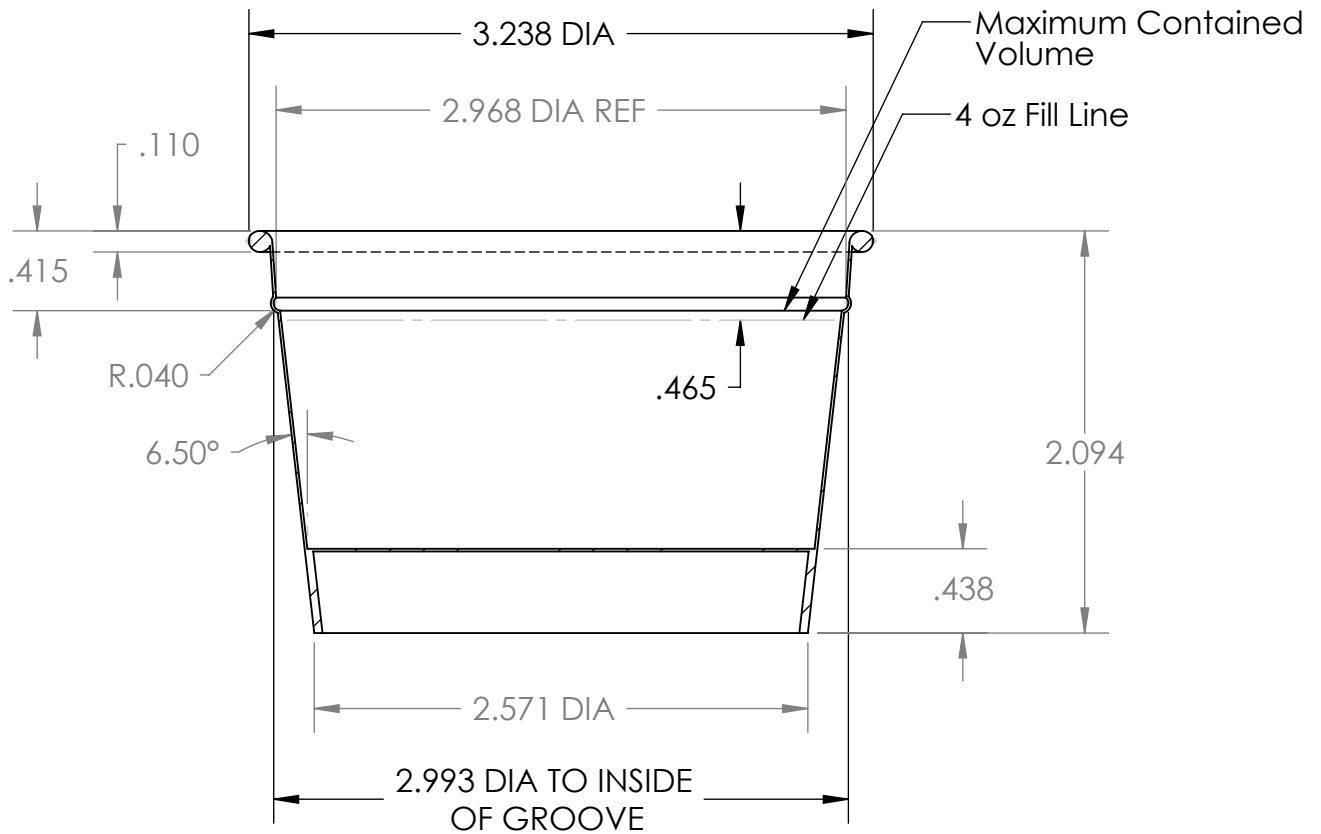

Cup Properties

Maximum Fill Volume	5.80 oz / 172 ml
Maximum Contained Volume (Bottom of Lid Groove)	4.18 oz / 124 ml
Practical Volume	4 oz / 118 ml
Stack Height	24.0" / 50 Cups
Sidewall Material 12.2 PT, Polycoated 2 Sides - 3/4 X 1/2 mm	
Bottom Material 11.3 PT, Polycoated 2 Sides - 3/4 X 1/2 mm	



PROPRIETARY AND CONFIDENTIAL		DWG #:	 www.stanpacnet.com	SIZE	REV
The information contained in this drawing is the sole property of Stanpac Inc. Any reproduction in part or as a whole without the express written consent of Stanpac Inc is strictly prohibited.		10040200		A	*
UNLESS OTHERWISE SPECIFIED: All Dimensions in Inches Tolerances as follows: Fractional ±1/16" Decimal X.X" ±0.02" X.XX" ±0.01" X.XXX" ±0.005" Angular Dimensions ± 0.5°	DATE:	MATERIAL:	4 oz / 118 ml Cup, Tab Lid Groove		
	7/31/2009	-----			
	DRAWN BY: Jon Heida	TITLE:			
USED ON:	-----	-----	SCALE:	1:1	
			SHEET	1 OF 1	