

Cup Properties

Maximum Fill Volume	4.69 oz / 139 ml
Maximum Contained Volume (Bottom of Lid Groove)	3.62 oz / 107 ml
Practical Volume	3.5 oz / 104 ml
Stack Height	17.6" / 50 Cups
Sidewall Material 12.2 PT, Polycoated 2 Sides - 3/4 X 1/2 mm	
Bottom Material 11.3 PT, Polycoated 2 Sides - 3/4 X 1/2 mm	

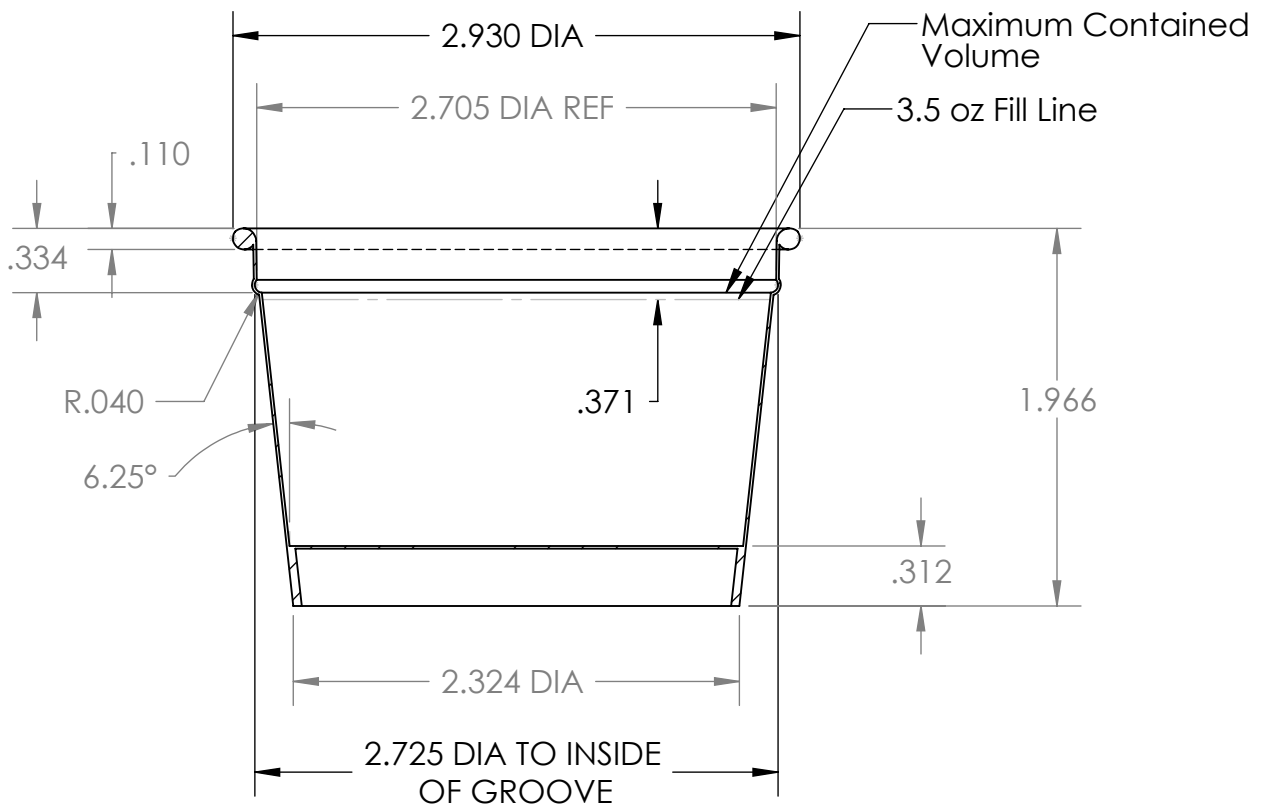

PROPRIETARY AND CONFIDENTIAL		 www.stanpacnet.com	SIZE	REV
The information contained in this drawing is the sole property of Stanpac Inc. Any reproduction in part or as a whole without the express written consent of Stanpac Inc is strictly prohibited.			A	*
UNLESS OTHERWISE SPECIFIED: All Dimensions in Inches Tolerances as follows: Fractional ±1/16" Decimal X.X" ±0.02" X.XX" ±0.01" X.XXX" ±0.005" Angular Dimensions ± 0.5°	DATE: 7/31/2009 DRAWN BY: Jon Heida USED ON:	DWG #: 10035200 MATERIAL:	TITLE: 3.5 oz / 104 ml Cup, Tab Lid Groove	
			SCALE: 1:1	SHEET 1 OF 1