

Cup Properties

Maximum Fill Volume	13.54 oz / 400 ml
Practical Volume	12.00 oz / 355 ml
Stack Height	21.6" / 50 Cups
Sidewall Material 16 PT, Polycoated 2 Sides - 3/4 X 1/2 mm	
Bottom Material 11.3 PT, Polycoated 2 Sides - 3/4 X 1/2 mm	

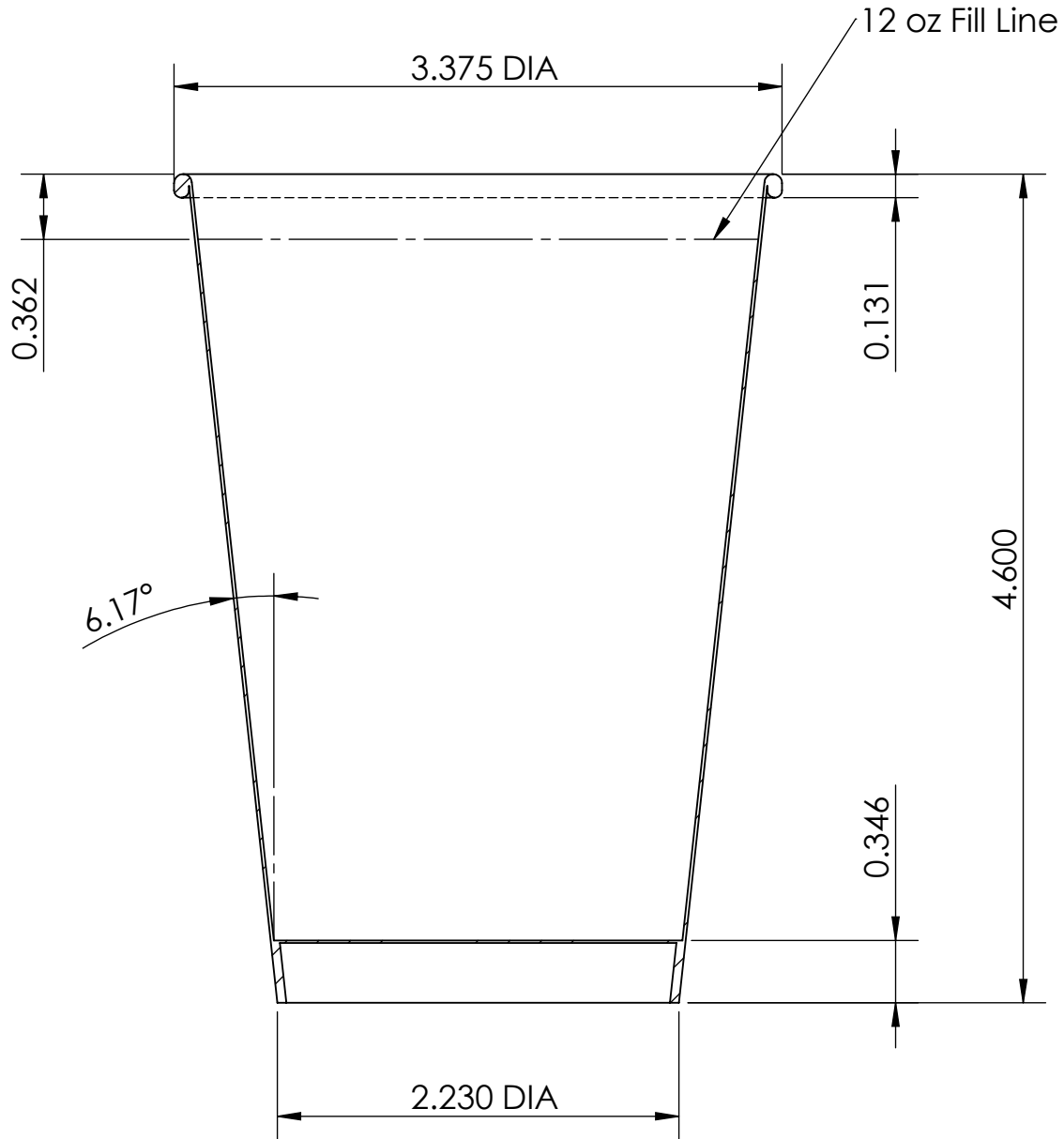

PROPRIETARY AND CONFIDENTIAL

The information contained in this drawing is the sole property of Stanpac Inc. Any reproduction in part or as a whole without the express written consent of Stanpac Inc is strictly prohibited.

UNLESS OTHERWISE SPECIFIED:

All Dimensions in Inches
 Tolerances as follows:
 Fractional ±1/16"
 Decimal X.X" ±0.02"
 X.XX" ±0.01"
 X.XXX" ±0.005"
 Angular Dimensions ± 0.5°

DATE: 7/31/2009
 DRAWN BY: Jon Heida
 USED ON: _____

DWG #: 10120100
 MATERIAL: _____
 TITLE: 12 oz / 355 ml Cup



SIZE	REV
A	*
SCALE: 1:1	
SHEET 1 OF 1	