



STANIPAC

COMPLETE PRODUCT CATALOGUE

ABOUT STANPAC ◀

Founded in 1949, Stanpac prides itself on providing incredible service and quality products. What first began as a manufacturer of milk bottle caps has since grown exponentially, offering ice cream, take-out and food service packaging, now employing over 800 people, serving more than 800 customers in over 30 countries.

Stanpac has remained a 100% privately held company with ownership belonging solely to the Witt brothers. We are dedicated to being good people who make great packaging; encouraging innovation, being leaders in the markets we serve and growing and developing our team of dedicated people.

SUSTAINABILITY ◀

PAPER PACKAGING Stanpac chooses Paper for many of their ice cream and food service packaging products. Paper is a renewable resource that can also be recycled in areas where programs exist. All Paperboard comes from companies that are SFI® certified. The Sustainable Forestry Initiative® program promotes sustainable forest management. By supporting the program, Stanpac is helping to strengthen forest practices in North America and promote responsible sourcing globally.

GLASS PACKAGING Glass is the trusted and proven packaging for health, taste and the environment. It is also the only widely-used food packaging granted the FDA status of “GRAS” (generally recognized as safe) – the highest standard. The refillable glass milk bottles take that a step further. Reusing a bottle over and over again saves raw materials and energy. When a bottle is taken out of service it can be recycled and made into a new container, starting the cycle all over again. Glass is 100% recyclable and can be recycled endlessly without loss in quality or purity. Glass containers are made with a combination of raw materials, including sand, soda ash, limestone and cullet (recycled glass), resulting in containers that are durable, strong, and impermeable.

TABLE OF CONTENTS ◀

ICE CREAM PACKAGING ◀

CUPS & LIDS

3 oz T Cup	6-7
3 oz T Cup Tab Lid Groove	8-9
3 oz S Cup	10-11
3 oz S Cup Tab Lid Groove	12-13
3 oz S Cup Spoon & Lid	14-15
3.5 oz Cup	16-17
3.5 oz Cup Tab Lid Groove	18-19
3.5 oz Cup Spoon & Lid	20-21
4 oz Cup	22-23
4 oz Cup Tab Lid Groove	24-25
4 oz Cup Spoon & Lid	26-27
8 oz Cup	28-29
8 oz Squat Cup	30
12 oz Cup (Heat Seal/Plastic Lid)	31-32
12 oz Squat Cup	33-34
12 oz Short Squat Cup	35
14 oz Cup	36
16 oz Cup	37
500 ml Cup	38
14, 16 oz & 500 ml Cup Lids	39
24 oz Cup	40-41
Quart Cup	42
Litre Cup	43
Litre & Quart Cup Lids	44
48 oz Cup Tall	45
56 oz Cup Tall	46
2 Litre Cup	47
48, 56 oz & 2 Litre Cup Lids	48
64 oz Cup	49-50
48 oz Cup Non Round	51
56 oz Cup Non Round	52
64 oz Cup Non Round	53
48, 56 & 64 oz Cup Non Round Lids	54-55
2.75 Gallon	56-57
Cup Lid Combinations	58-59

ADDITIONAL LIDS & SEALS

Tab Lids	62-63
Disc Lids	64-65
Tear Drop Heat Seal Lids	66-67
Die Cut Heat Seal Lids	68-69
Non-Round Heatseal	70

DAIRY PACKAGING ◀

GLASS MILK BOTTLES

8 oz Half Pint Glass	74
12 oz Glass	75
12 oz Threaded Glass	76
16 oz Squat Pint Glass	77
16 oz Threaded Squat Pint Glass	78
16 oz Tall Pint Glass	79
16 oz Threaded Tall Pint Glass	80
32 oz Square Quart Glass	81
32 oz Round Quart Glass	82
1 Litre, 34 oz Glass	83
64 oz Half Gallon Glass	84-85

DAIRY PACKAGING

8 oz Glass Jar	86
4.70 oz Glass Jar	87-88

CAPS, CARRIERS & CASES

38 mm Tamper Evident Caps	89
48 mm Tamper Evident Caps	90
48 mm Threaded Tamper Evident Caps	91
Square Quart Wire Carrier	92
Half Gallon Wire Carrier	93
6 Cell Half Gallon Plastic Divided Case	94
12 Cell Square Quart Plastic Divided Case	95

FOOD SERVICE PACKAGING ◀

PAPER HOT CUPS

4 oz Paper Hot Cup	98
6 oz Paper Hot Cup	99
8 oz Paper Hot Cup	100
8 oz Double Wall Thermal Hot Cup	101
10 oz Tall Paper Hot Cup	102
10 oz Squat Paper Hot Cup	103
12 oz Paper Hot Cup	104
12 oz Double Wall Thermal Hot Cup	105
16 oz Paper Hot Cup	106
16 oz Double Wall Thermal Hot Cup	107
20 oz Paper Hot Cup	108
20 oz Double Wall Thermal Hot Cup	109
24 oz Paper Hot Cup	110
24oz Double Wall Thermal Cup	111

PAPER HOT CUP LIDS

Foldback Lids	112
Dome Lids	113
Foldback Dome Lids	114

TAKE-OUT PACKAGING

8 oz Paper Food Container Cup	115
8 oz Paper Food Container Combo Pack	116
12 oz Paper Food Container Cup	117
12 oz Paper Food Container Combo Pack	118
16 oz Paper Food Container Cup	119
16 oz Paper Food Container Combo Pack	120
32 oz Paper Food Container Cup	121

TAKE-OUT PACKAGING LIDS

Vented Food Container Lids	122
Plastic Food Container Lids	123





A young girl with blonde hair in two braids, wearing black-rimmed glasses and a dark suit with a light-colored bow tie. She is holding a chocolate ice cream cone in her right hand and a single broccoli floret in her left hand. The entire image is overlaid with a semi-transparent red filter.

ICE CREAM PACKAGING ◀



3 OZ / 89 ML CUP

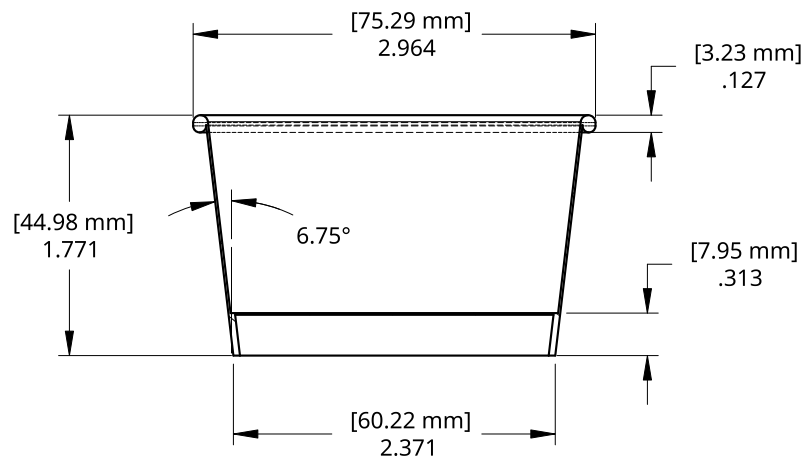

3 OZ T CUP ◀

CUP PROPERTIES:

Maximum Fill Volume: 4.27 oz / 126 ml

Practical Volume: 3.0 oz / 89 ml

Stack Height: 17.11" / 50 Cups

Sidewall Material: 12.5 PT, Polycoated 2 Sides, 1/2 x 3/4 mil

Bottom Material: 12.5 PT, Polycoated 2 Sides, 1/2 x 3/4 mil

PACKAGING CONFIGURATIONS:

3 oz T Cups:

2,400 Per Case – 48,000 Per Pallet

4 Cases Per Layer

5 Layers Per Pallet

20 Cases Per Pallet

25 lbs Per Case

535 lbs Per Pallet

Pallet Dimensions: 40" x 48" x 96"

Box Size: 24" x 18" x 18"

3 oz T Cups - Food Service Pack:

1,000 Per Case – 55,000 Per Pallet

11 Cases Per Layer

5 Layers Per Pallet

55 Cases Per Pallet

11 lbs Per Case

640 lbs Per Pallet

Pallet Dimensions: 42" x 48" x 98"

Box Size: 15" x 12" x 18"



75 MM PLUG LID

3 OZ T CUP ◀

75 MM PLUG LID PROPERTIES:

Plastic Material: LLDPE

PACKAGING CONFIGURATIONS:

75 mm Plug Lid:

1,000 Per Case – 27,000 Per Pallet

9 Cases Per Layer

3 Layers Per Skid

27 Cases Per Pallet

15 lbs Per Case

440 lbs Per Pallet

Pallet Dimensions: 40" x 48" x 44"

Box Size: 16" x 14" x 13"

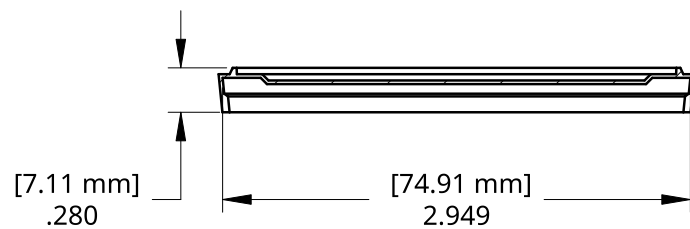
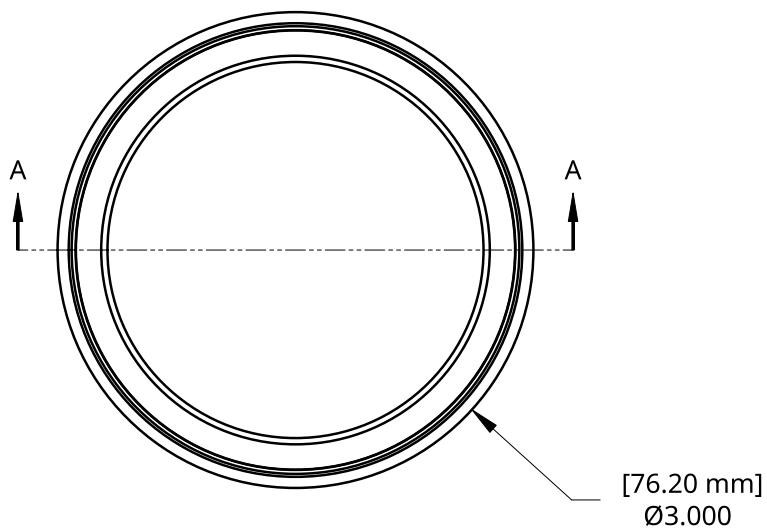



3 OZ T TAB LID GROOVE ◀

CUP PROPERTIES:

Maximum Fill Volume: 4.27 oz / 126 ml
 Maximum Contained Volume
 (Bottom of Lid Groove): 3.14 oz / 92 ml
 Practical Volume: 3.0 oz / 89 ml
 Stack Height: 17.11" / 50 Cups
 Sidewall Material: 12.5 PT, Polycoated 2 Sides, 1/2 x 3/4 mil
 Bottom Material: 12.5 PT, Polycoated 2 Sides, 1/2 x 3/4 mil

PACKAGING CONFIGURATIONS:

3 oz Cups:

2,400 Per Case – 48,000 Per Pallet
 4 Cases Per Layer
 5 Layers Per Pallet
 20 Cases Per Pallet
 25 lbs Per Case
 535 lbs Per Pallet
 Pallet Dimensions: 48" x 43" x 96"
 Box Size: 24" x 18" x 18"

3 OZ / 89 ML CUP

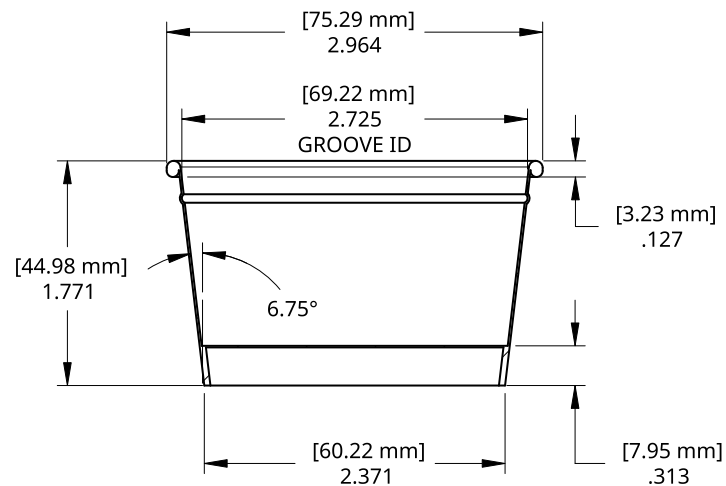



70 MM (2.76") TAB LID

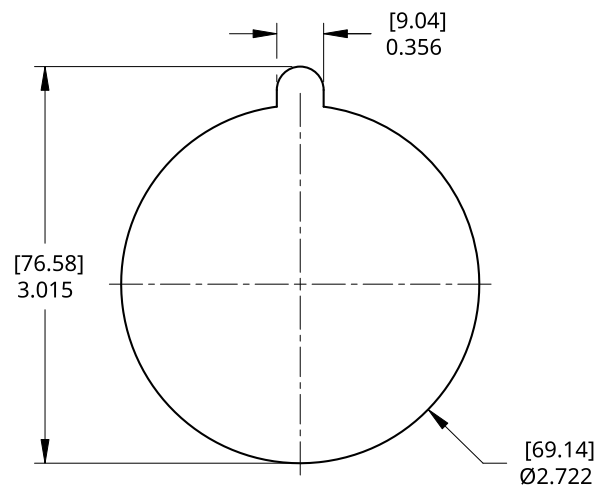

3 OZ T TAB LID GROOVE ◀

70 MM TAB LID PROPERTIES:

Disc Material: 18 PT, Polycoated 2 Sides,
1/2 x 1/2 mil

PACKAGING CONFIGURATIONS:

70 mm (2.76") Tab Lid:

10,000 Per Case – 550,000 Per Pallet

11 Cases Per Layer

5 Layers Per Pallet

55 Cases Per Pallet

32 lbs Per Case

1795 lbs Per Pallet

Pallet Dimensions: 48" x 40" x 55"

Box Size: 14" x 12" x 10"



3 OZ / 89 ML CUP

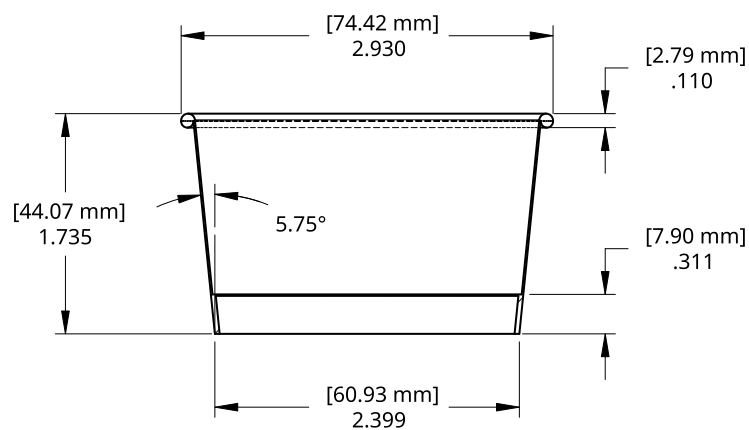

3 OZ S CUP ◀

CUP PROPERTIES:

Maximum Fill Volume: 4.12 oz / 122 ml

Practical Volume: 3 oz / 89 ml

Stack Height: 17.3" / 50 Cups

Sidewall Material: 12.5 PT, Polycoated 2 sides, 1/2 x 3/4 mil

Bottom Material: 12.5 PT, Polycoated 2 sides, 1/2 x 3/4 mil

PACKAGING CONFIGURATIONS:

3 oz S Cups:

2,400 Per Case – 48,000 Per Pallet

4 Cases Per Layer

5 Layers Per Pallet

20 Cases Per Pallet

25 lbs Per Case

535 lbs Per Pallet

Pallet Dimensions: 40" x 48" x 96"

Box Size: 24" x 18" x 18"

3 oz S Cups - Food Service Pack:

1,000 Per Case – 55,000 Per Pallet

11 Cases Per Layer

5 Layers Per Pallet

55 Cases Per Pallet

11 lbs Per Case

640 lbs Per Pallet

Pallet Dimensions: 48" x 43" x 96"

Box Size: 15" x 12" x 18"



75 MM PAPER LID

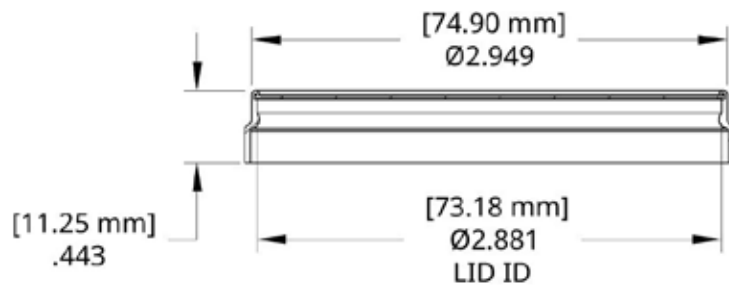

3 OZ S CUP ◀

75 MM PAPER LID PROPERTIES:

Lid Material: 16 PT, Polycoated 2 sides, 1/2 x 1/2mil

PACKAGING CONFIGURATIONS:

75 mm Paper Lid:

1,000 Per Case – 63,000 Per Pallet

9 Cases Per Layer

7 Layers Per Skid

63 Cases Per Pallet

9 lbs Per Case

602 lbs Per Pallet

Pallet Dimensions: 48" x 40" x 96"

Box Size: 16" x 13" x 13"



3 OZ S TAB LID GROOVE ◀

CUP PROPERTIES:

Maximum Fill Volume: 4.12 oz / 122 ml
 Maximum Contained Volume
 (Bottom of Lid Groove): 3.14 oz / 92 ml
 Practical Volume: 3.0 oz / 89 ml
 Stack Height: 17.3" / 50 Cups
 Sidewall Material: 12.5 PT, Polycoated 2 Sides, 1/2 x 3/4 mil
 Bottom Material: 12.5 PT, Polycoated 2 Sides, 1/2 x 3/4 mil

3 OZ / 89 ML CUP

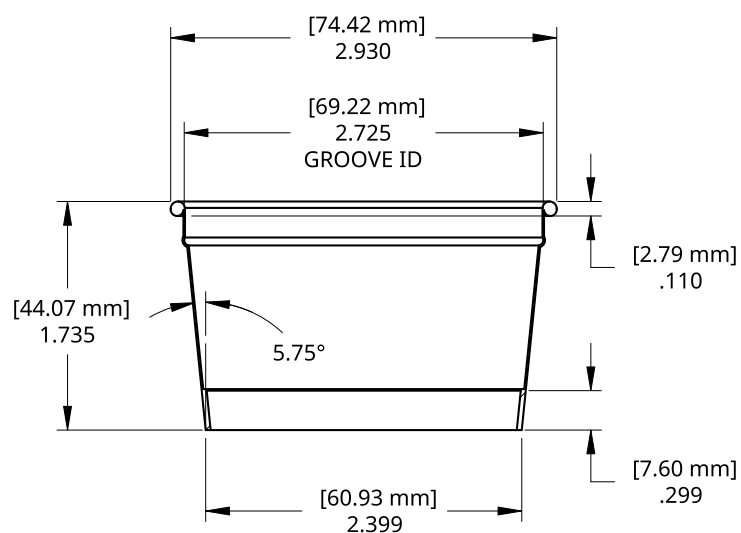

PACKAGING CONFIGURATIONS:

3 oz Cups:

2,400 Per Case – 48,000 Per Pallet
 4 Cases Per Layer
 5 Layers Per Pallet
 20 Cases Per Pallet
 25 lbs Per Case
 535 lbs Per Pallet
 Pallet Dimensions: 40" x 48" x 96"
 Box Size: 24" x 18" x 18"



70 MM (2.76") TAB LID

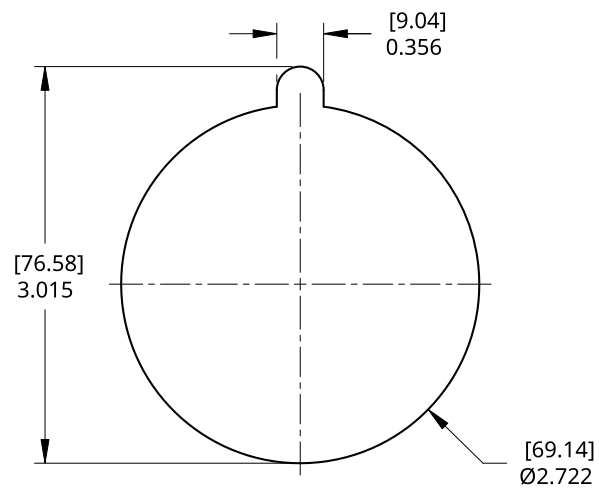

3 OZ S TAB LID GROOVE ◀

70 MM TAB LID PROPERTIES:

Disc Material: 18 PT, Polycoated 2 Sides,
1/2 x 1/2 mil

PACKAGING CONFIGURATIONS:

70 mm (2.76") Tab Lid:

10,000 Per Case – 550,000 Per Pallet

11 Cases Per Layer

5 Layers Per Pallet

55 Cases Per Pallet

32 lbs Per Case

1795 lbs Per Pallet

Pallet Dimensions: 48" x 40" x 55"

Box Size: 12" x 14" x 10"



3 OZ / 89 ML CUP

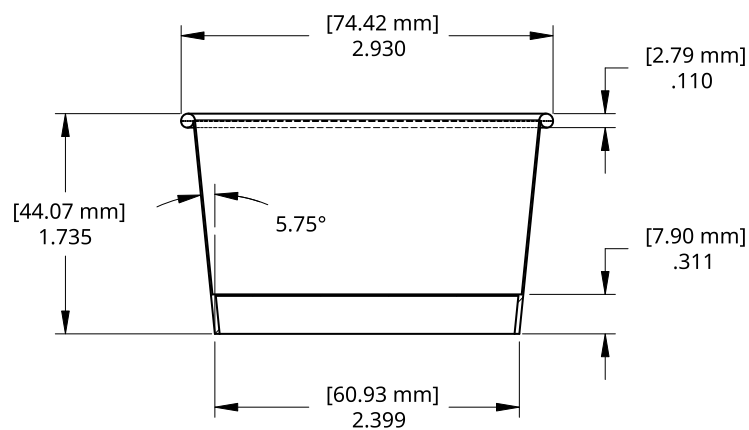

3 OZ S CUP SPOON & LID ◀

CUP PROPERTIES:

Maximum Fill Volume: 4.12 oz / 122 ml
 Maximum Contained Volume
 (Bottom of Lid Groove): 3.14 oz / 92 ml
 Practical Volume: 3.0 oz / 89 ml
 Stack Height: 17.3" / 50 Cups
 Sidewall Material: 12.5 PT, Polycoated 2 Sides, 1/2 x 3/4 mil
 Bottom Material: 12.5 PT, Polycoated 2 Sides, 1/2 x 3/4 mil

PACKAGING CONFIGURATIONS:

3 oz Cups:

2,400 Per Case – 48,000 Per Pallet
 4 Cases Per Layer
 5 Layers Per Pallet
 20 Cases Per Pallet
 25 lbs Per Case
 535 lbs Per Pallet
 Pallet Dimensions: 40" x 48" x 96"
 Box Size: 24" x 18" x 18"

3 oz Cups - Food Service Pack:

1,000 Per Case – 55,000 Per Pallet
 11 Cases Per Layer
 5 Layers Per Pallet
 55 Cases Per Pallet
 11 lbs Per Case
 640 lbs Per Pallet
 Pallet Dimensions: 48" x 42" x 98"
 Box Size: 15" x 12" x 18"

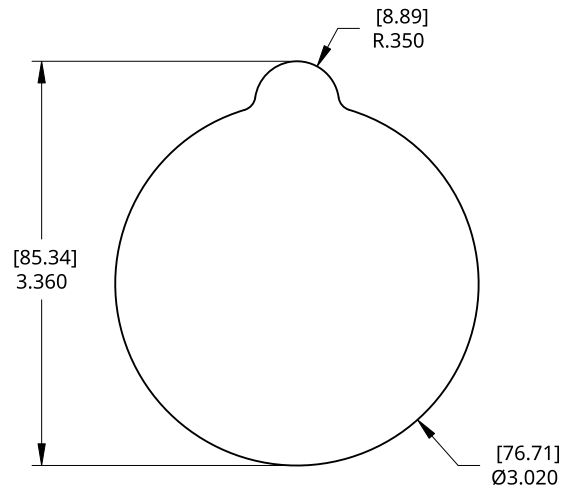

76.7 MM (3.02") HEAT SEAL

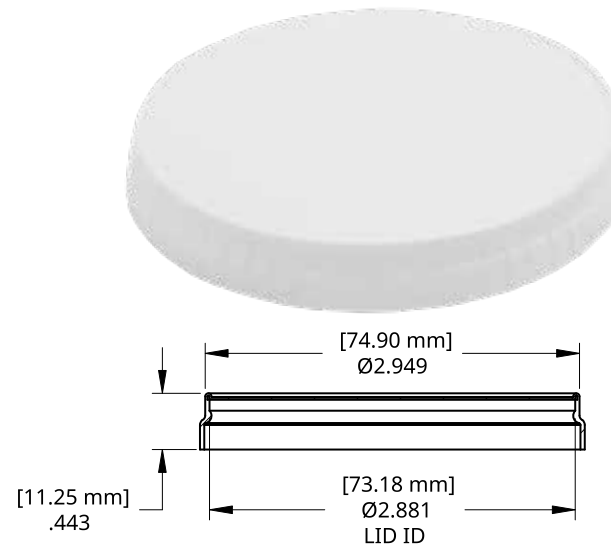

75 MM PAPER LID



60 MM SPOON

3 OZ S CUP SPOON & LID ◀

76.7 MM HEAT SEAL PROPERTIES:

Paper Material: PPP

PACKAGING CONFIGURATIONS:

76.7 mm (3.02") Heat Seal Lid

16,200 Per Case
777,600 Per Pallet
12 Cases Per Layer
4 Layers Per Pallet
48 Cases Per Pallet
Pallet Dimensions: 48" x 40" x 45"
Box Size: 14" x 10" x 10"

75 MM PAPER LID PROPERTIES:

Lid Material: 16Pt, Polycoated 2 Sides, 1/2 x 1/2mil

PACKAGING CONFIGURATIONS:

75 Paper Lid:

1,000 Per Case – 63,000 Per Pallet
9 Cases Per Layer
7 Layers Per Skid
63 Cases Per Pallet
9 lbs Per Case
627 lbs Per Pallet
Pallet Dimensions: 48" x 40" x 94.125"
Box Size: 16" x 13" x 13"

60 MM SPOON:

Material: Wood

60 mm Spoon:

10,000 Per Case
600,000 Per Pallet
20 Cases Per Layer
3 Layers Per Skid
60 Cases Per Pallet
17 lbs Per Case
1490 lbs Per Pallet
Pallet Dimensions:
48" x 40" x 44"
Box Size:
12" x 7" x 13"



3.5 OZ / 104 ML CUP

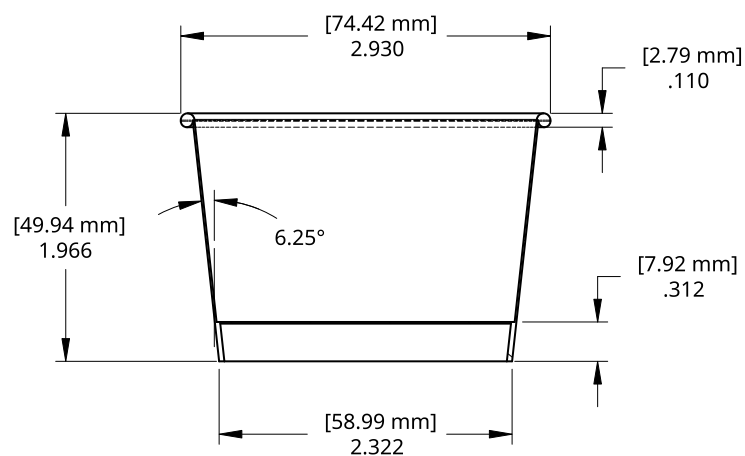

3.5 OZ CUP ◀

CUP PROPERTIES:

Maximum Fill Volume: 4.69 oz / 139 ml
 Practical Volume: 3.5 oz / 104 ml
 Stack Height: 17.25" / 50 Cups
 Sidewall Material: 12.5 PT, Polycoated 2 Sides, 1/2 x 3/4 mil
 Bottom Material: 12.5 PT, Polycoated 2 Sides, 1/2 x 3/4 mil

PACKAGING CONFIGURATIONS:

3.5 oz Cups:

2,400 Per Case – 48,000 Per Pallet
 4 Cases Per Layer
 5 Layers Per Pallet
 20 Cases Per Pallet
 25 lbs Per Case
 535 lbs Per Pallet
 Pallet Dimensions: 40" x 48" x 96"
 Box Size: 24" x 18" x 18"

3.5 oz Cups - Food Service Pack Sleeved Lid:

1,000 Per Case – 55,000 Per Pallet
 11 Cases Per Layer
 5 Layers Per Pallet
 55 Cases Per Pallet
 11 lbs Per Case
 640 lbs Per Pallet
 Pallet Dimensions: 42" x 48" x 98"
 Box Size: 15" x 12" x 18"



75 MM PAPER LID

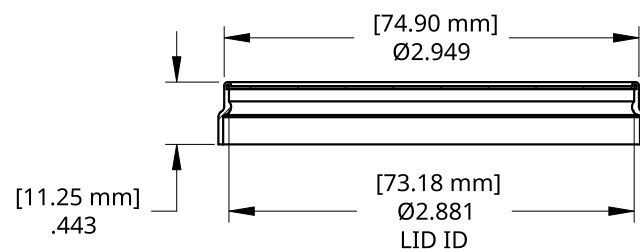

3.5 OZ CUP ◀

75 MM PAPER LID PROPERTIES:

Lid Material: 16Pt, Polycoated 2 Sides, 1/2 x 1/2mil

PACKAGING CONFIGURATIONS:

75 mm Paper Lid:

1,000 Per Case – 63,000 Per Pallet

9 Cases Per Layer

7 Layers Per Skid

63 Cases Per Pallet

9 lbs Per Case

602 lbs Per Pallet

Pallet Dimensions: 48" x 40" x 94"

Box Size: 16" x 13" x 13"



3.5 OZ CUP TAB LID GROOVE ◀

CUP PROPERTIES:

Maximum Fill Volume: 4.69 oz / 139 ml
 Maximum Contained Volume
 (Bottom of Lid Groove): 3.62 oz / 107 ml
 Practical Volume: 3.5 oz / 104 ml
 Stack Height: 17.6" / 50 Cups
 Sidewall Material: 12.5 PT, Polycoated 2 Sides, 1/2 x 3/4 mil
 Bottom Material: 12.5 PT, Polycoated 2 Sides, 1/2 x 3/4 mil

PACKAGING CONFIGURATIONS:

3.5 oz Cups:

2,400 Per Case – 48,000 Per Pallet
 4 Cases Per Layer
 5 Layers Per Pallet
 20 Cases Per Pallet
 25 lbs Per Case
 535 lbs Per Pallet
 Pallet Dimensions: 40" x 48" x 96"
 Box Size: 24" x 18" x 18"

3.5 OZ / 104 ML CUP

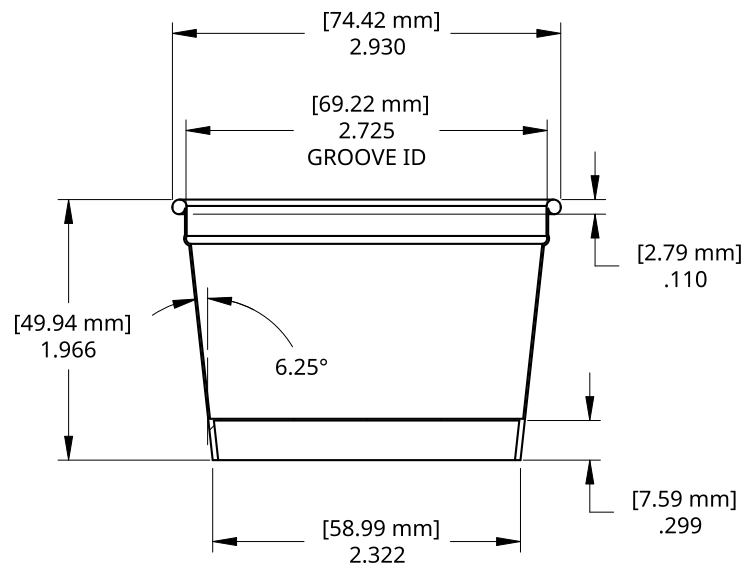



70 MM (2.76") TAB LID

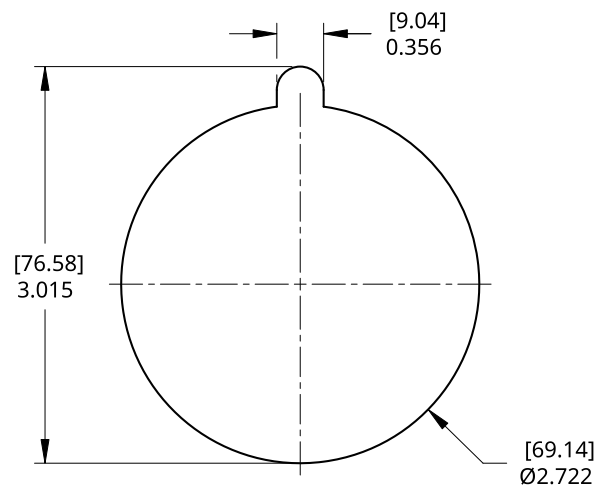

3.5 OZ CUP TAB LID GROOVE ◀

70 MM (2.76") TAB LID PROPERTIES:

Disc Material: 18 PT, Polycoated 2 Sides, 1/2 x 1/2 mil

PACKAGING CONFIGURATIONS:

70 mm Tab Lid:

10,000 Per Case – 550,000 Per Pallet

11 Cases Per Layer

5 Layers Per Pallet

55 Cases Per Pallet

32 lbs Per Case

1795 lbs Per Pallet

Pallet Dimensions: 48" x 40" x 55"

Box Size: 12" x 14" x 10"



3.5 OZ / 104 ML CUP

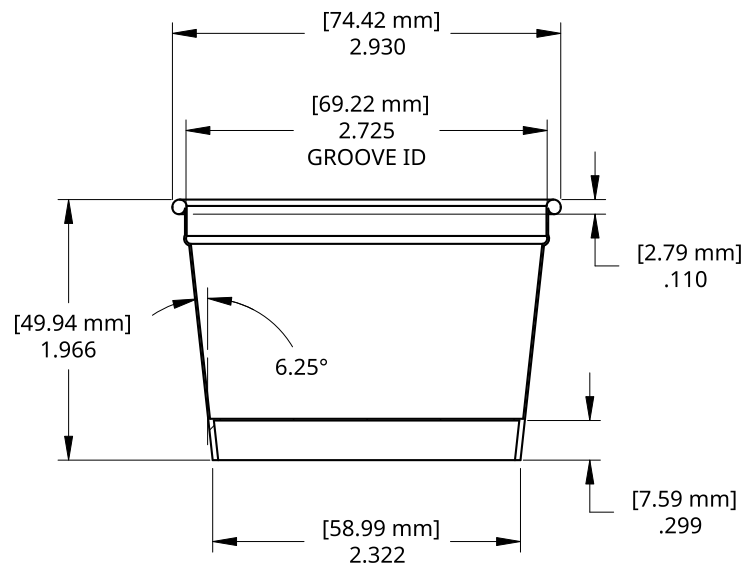

3.5 OZ GROOVE CUP ◀

CUP PROPERTIES:

Maximum Fill Volume: 4.69 oz / 139 ml
 Maximum Contained Volume
 (Bottom of Lid Groove): 3.62 oz / 107 ml
 Practical Volume: 3.5 oz / 104 ml
 Stack Height: 17.6" / 50 Cups
 Sidewall Material: 12.5 PT, Polycoated 2 Sides, 1/2 x 3/4 mil
 Bottom Material: 12 PT, Polycoated 2 Sides, 1/2 x 3/4 mil

PACKAGING CONFIGURATIONS:

3.5 oz Cups:

2,400 Per Case
 48,000 Per Pallet
 4 Cases Per Layer
 5 Layers Per Pallet
 20 Cases Per Pallet
 25 lbs Per Case
 535 lbs Per Pallet
 Pallet Dimensions: 40" x 48" x 96"
 Box Size: 24" x 18" x 18"

3.5 oz Cups - Food Service Pack:

1,000 Per Case
 55,000 Per Pallet
 11 Cases Per Layer
 5 Layers Per Pallet
 55 Cases Per Pallet
 11 lbs Per Case
 640 lbs Per Pallet
 Pallet Dimensions: 42" x 48" x 98"
 Box Size: 15" x 12" x 18"

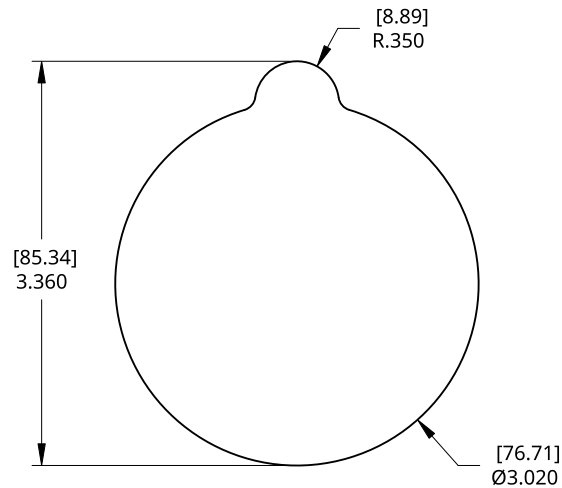

76.7 MM (3.02") HEAT SEAL

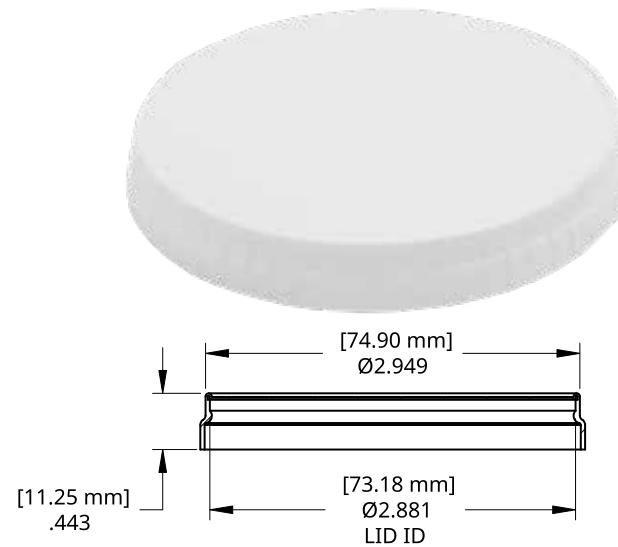

75 MM PAPER LID



60 MM SPOON

3.5 OZ S CUP SPOON & LID ◀

76.7 MM HEAT SEAL PROPERTIES:

Paper Material: PPP

PACKAGING CONFIGURATIONS:

76.7 mm (3.02") Heat Seal Lid

16,200 Per Case
777,600 Per Pallet
12 Cases Per Layer
4 Layers Per Pallet
48 Cases Per Pallet
Pallet Dimensions: 48" x 40" x 45"
Box Size: 14" x 10" x 10"

75 MM PAPER LID PROPERTIES:

Lid Material: 16Pt, P2S 1/2 x 1/2mil

PACKAGING CONFIGURATIONS:

75 mm Paper Lid:

1,000 Per Case – 63,000 Per Pallet
9 Cases Per Layer
7 Layers Per Skid
63 Cases Per Pallet
9 lbs Per Case
602 lbs Per Pallet
Pallet Dimensions: 48" x 40" x 94"
Box Size: 16" x 13" x 13"

60 MM SPOON:

Material: Wood

60 mm Spoon:

10,000 Per Case
600,000 Per Pallet
20 Cases Per Layer
3 Layers Per Skid
60 Cases Per Pallet
17 lbs Per Case
1490 lbs Per Pallet
Pallet Dimensions:
48" x 40" x 44"
Box Size:
12" x 7" x 13"



4 OZ / 118 ML CUP

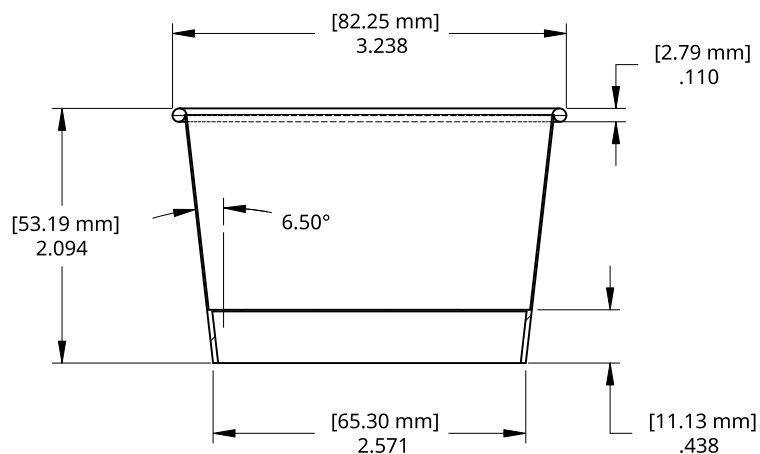

4 OZ CUP ◀

CUP PROPERTIES:

Maximum Fill Volume: 5.80 oz / 172 ml
 Practical Volume: 4.0 oz / 118 ml
 Stack Height: 23.6" / 50 Cups
 Sidewall Material: 12.5 PT, Polycoated 2 Sides, 1/2 x 3/4 mil
 Bottom Material: 12.5 PT, Polycoated 2 Sides, 1/2 x 3/4 mil

PACKAGING CONFIGURATIONS:

4 oz Cups:

2,000 Per Case – 32,000 Per Pallet
 4 Cases Per Layer
 4 Layers Per Pallet
 16 Cases Per Pallet
 28 lbs Per Case
 483 lbs Per Pallet
 Pallet Dimensions: 48" x 40" x 102"
 Box Size: 23" x 20" x 24"

4 oz Cups - Food Service Pack:

1,000 Per Case – 32,000 Per Pallet
 8 Cases Per Layer
 4 Layers Per Pallet
 32 Cases Per Pallet
 15 lbs Per Case
 515 lbs Per Pallet
 Pallet Dimensions: 40" x 48" x 101"
 Box Size: 17" x 14" x 24"

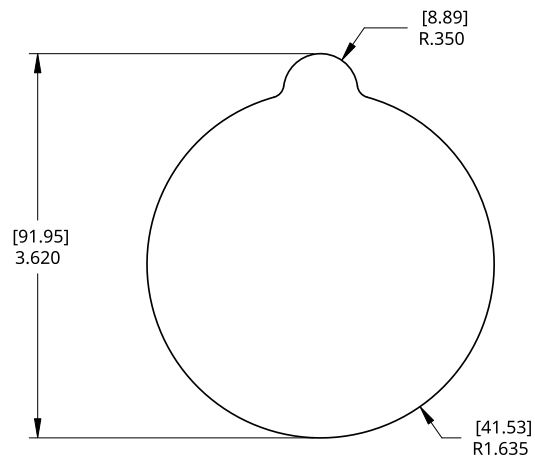

83 MM (3.27") HEAT SEAL



82 MM PAPER LID

4 OZ CUP LID ◀

83 MM HEAT SEAL PROPERTIES:

Paper Material: PPP

PACKAGING CONFIGURATIONS:

83 mm (3.22") Heat Seal Lid

8,100 Per Case
 518,400 Per Pallet
 16 Cases Per Layer
 4 Layers Per Pallet
 64 Cases Per Pallet
 13.5 lbs Per Case
 899 lbs Per Pallet
 Pallet Dimensions: 48" x 40" x 45"
 Box Size: 12" x 8" x 9"

82 MM PAPER LID PROPERTIES:

Lid Material: 16Pt, Polycoated 2 Sides, 1/2 x 1/2mil

PACKAGING CONFIGURATIONS:

82 mm Coverall Lid - Standard Pack Bulk Lid:

1,000 Per Case – 42,000 Per Pallet
 8 Cases Per Layer
 6 Layers Per Skid
 48 Cases Per Pallet
 11 lbs Per Case
 563 lbs Per Pallet
 Pallet Dimensions: 48" x 40" x 89"
 Box Size: 17" x 13" x 14"



4 OZ TAB LID GROOVE ◀

CUP PROPERTIES:

Maximum Fill Volume: 5.80 oz / 172 ml
 Maximum Contained Volume
 (Bottom of Lid Groove): 4.18 oz / 124 ml
 Practical Volume: 4.0 oz / 118 ml
 Stack Height: 23.6" / 50 Cups
 Sidewall Material: 12.5 PT, Polycoated 2 Sides, 1/2 x 3/4 mil
 Bottom Material: 12 PT, Polycoated 2 Sides, 1/2 x 3/4 mil

PACKAGING CONFIGURATIONS:

4 oz Cups:

2,000 Per Case – 32,000 Per Pallet
 4 Cases Per Layer
 4 Layers Per Pallet
 16 Cases Per Pallet
 28 lbs Per Case
 483 lbs Per Pallet
 Pallet Dimensions: 48" x 40" x 102"
 Box Size: 23" x 20" x 24"

4 OZ / 118 ML CUP

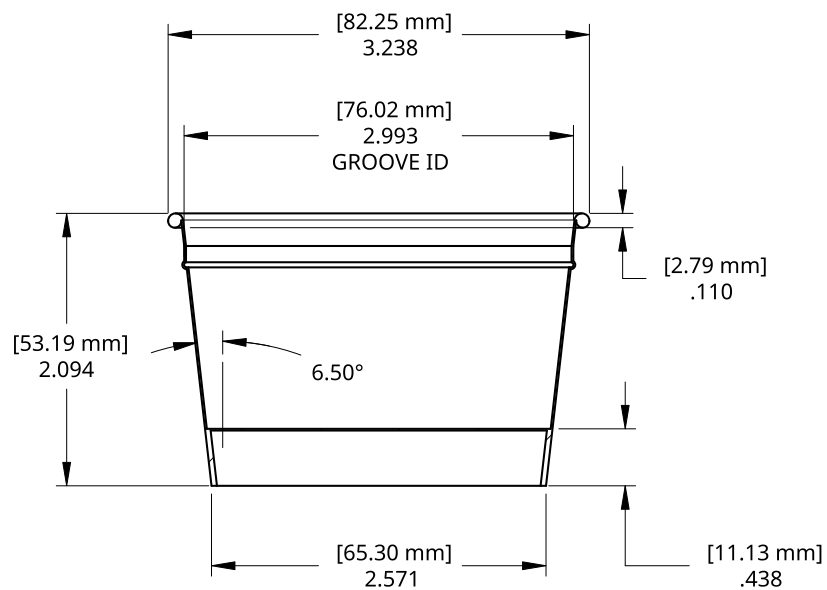



75.5 MM (3.02") TAB LID

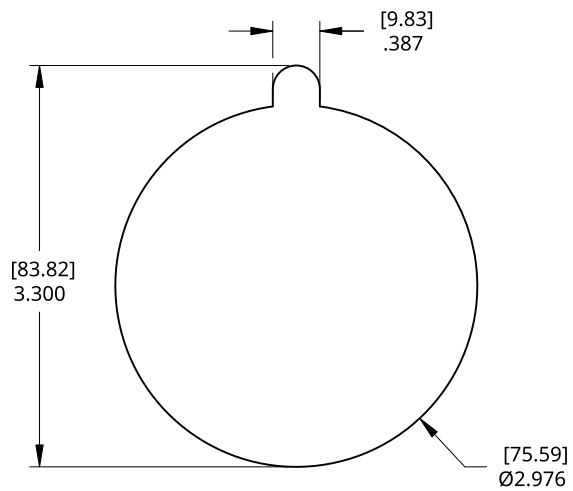

4 OZ TAB LID GROOVE ◀

75.5 MM TAB LID PROPERTIES

Disc Material: 18 PT, Polycoated 2 Sides, 1/2 x 1/2 mil

PACKAGING CONFIGURATIONS:

75.5 mm Tab Lid:

10,000 Per Case – 360,000 Per Pallet

9 Cases Per Layer

4 Layers Per Pallet

36 Cases Per Pallet

39 lbs Per Case

1439 lbs Per Pallet

Pallet Dimensions: 48" x 40" x 48"

Box Size: 13" x 16" x 10"



4 OZ / 118 ML CUP

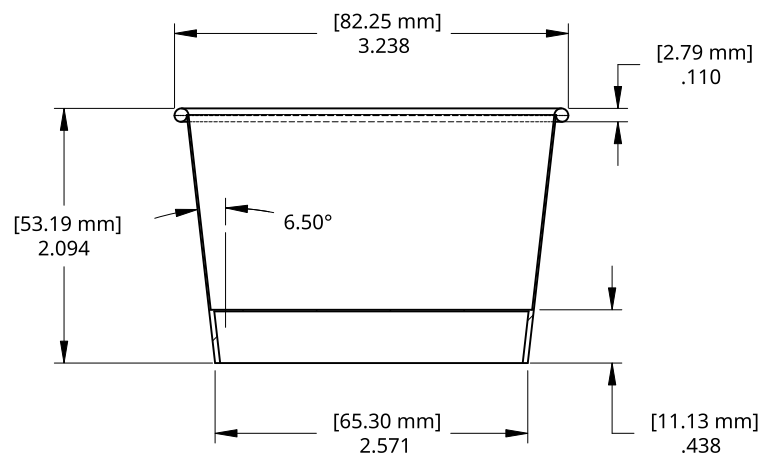

4 OZ CUP SPOON & LID ◀

CUP PROPERTIES:

Maximum Fill Volume: 5.80 oz / 172 ml
 Maximum Contained Volume
 (Bottom of Lid Groove): 4.18 oz / 124 ml
 Practical Volume: 4.0 oz / 118 ml
 Stack Height: 23.6" / 50 Cups
 Sidewall Material: 12.5 PT, Polycoated 2 Sides, 1/2 x 3/4 mil
 Bottom Material: 12.5 PT, Polycoated 2 Sides, 1/2 x 3/4 mil

PACKAGING CONFIGURATIONS:

4 oz Cups:

2,000 Per Case – 32,000 Per Pallet
 4 Cases Per Layer
 4 Layers Per Pallet
 16 Cases Per Pallet
 28 lbs Per Case
 483 lbs Per Pallet
 Pallet Dimensions: 48" x 40" x 102"
 Box Size: 23" x 20" x 24"

4 oz Cups - Food Service Pack:

1,000 Per Case – 32,000 Per Pallet
 8 Cases Per Layer
 4 Layers Per Pallet
 32 Cases Per Pallet
 15 lbs Per Case
 515 lbs Per Pallet
 Pallet Dimensions: 40" x 48" x 101"
 Box Size: 17" x 14" x 24"

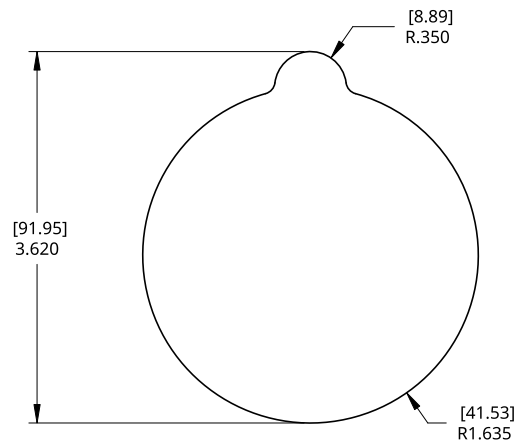

83 MM (3.27") HEAT SEAL

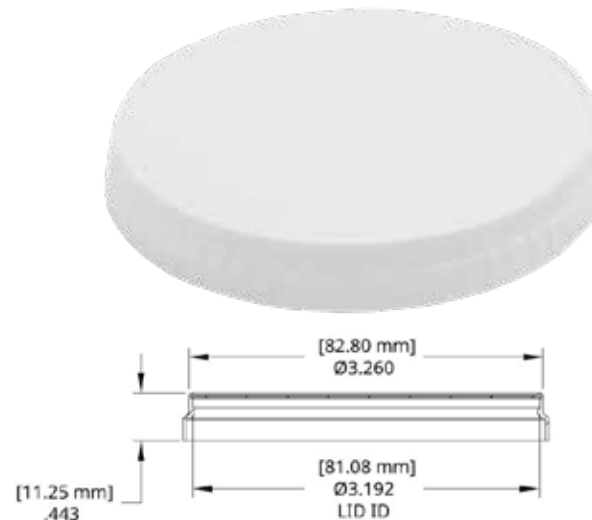

82 MM PAPER LID



60 MM SPOON

4 OZ CUP SPOON & LID ◀

83 MM HEAT SEAL PROPERTIES:

Paper Material: PPP

PACKAGING CONFIGURATIONS:

83 mm (3.22") Heat Seal Lid

8,100 Per Case
518,400 Per Pallet
16 Cases Per Layer
4 Layers Per Pallet
64 Cases Per Pallet
13.5 lbs Per Case
899 lbs Per Pallet
Pallet Dimensions: 48" x 40" x 45"
Box Size: 12" x 8" x 9"

82 MM PAPER LID PROPERTIES:

Lid Material: 16Pt, Polycoated 2 Sides, 1/2 x 1/2mil

PACKAGING CONFIGURATIONS:

82 mm Coverall Lid - Standard Pack Bulk Lid:

1,000 Per Case – 48,000 Per Pallet
8 Cases Per Layer
6 Layers Per Skid
48 Cases Per Pallet
11 lbs Per Case
522 lbs Per Pallet
Pallet Dimensions: 48" x 40" x 89"
Box Size: 17" x 13" x 14"

60 MM SPOON:

Material: Wood

60 mm Spoon:

10,000 Per Case
600,000 Per Pallet
20 Cases Per Layer
3 Layers Per Skid
60 Cases Per Pallet
17 lbs Per Case
1490 lbs Per Pallet
Pallet Dimensions:
48" x 40" x 45"
Box Size:
12" x 7" x 13"



8 OZ / 237 ML CUP

8 OZ CUP ◀

CUP PROPERTIES:

Maximum Fill Volume: 8.60 oz / 254 ml
 Practical Volume: 8 oz / 237 ml
 Stack Height: 20.2" / 50 Cups
 Sidewall Material: 16 PT, Polycoated 2 Sides, 1/2 x 3/4 mil
 Bottom Material: 12.5 PT, Polycoated 2 Sides, 1/2 x 3/4 mil

PACKAGING CONFIGURATIONS:

8 oz Cups:

1,000 Per Case – 24,000 Per Pallet
 6 Cases Per Layer
 4 Layers Per Pallet
 24 Cases Per Pallet
 21 lbs Per Case
 539 lbs Per Pallet
 Pallet Dimensions: 48" x 40" x 89"
 Box Size: 17" x 14" x 21"

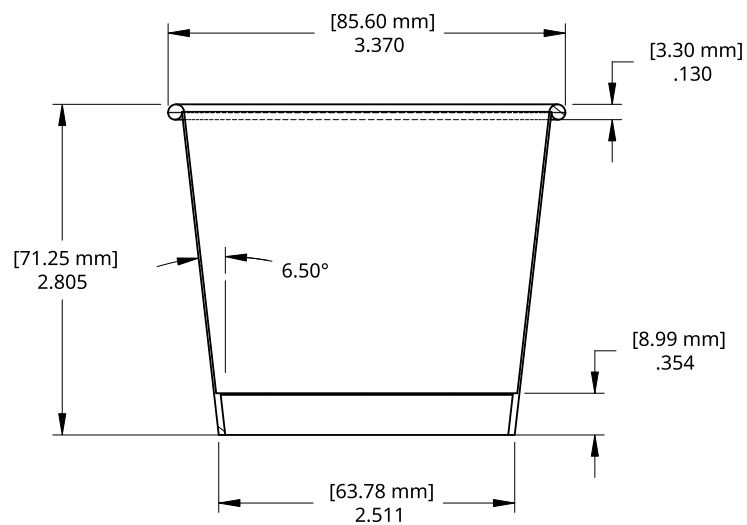

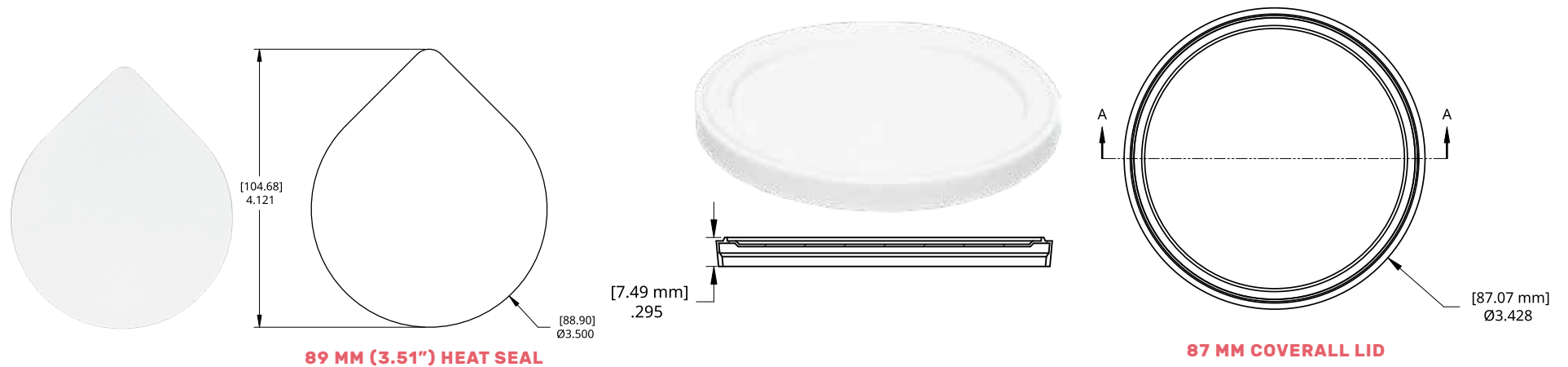

8 OZ CUP ◀

89 MM HEAT SEAL PROPERTIES:

Paper Material: 70# Multiflex Gloss

PACKAGING CONFIGURATIONS:

89 mm (3.51") Teardrop Heat Seal Lid

9,000 Per Case – 576,000 Per Pallet

16 Cases Per Layer

4 Layers Per Pallet

64 Cases Per Pallet

17 lbs Per Case

1123 lbs Per Pallet

Pallet Dimensions: 48" x 40" x 42"

Box Size: 12" x 8" x 9"

87 MM COVERALL LID PROPERTIES:

Plastic Material: LLDPE

PACKAGING CONFIGURATIONS:

87 mm Coverall Lid - Standard Pack Sleeved*:

1,000 Per Case – 42,000 Per Pallet

7 Cases Per Layer

6 Layers Per Skid

42 Cases Per Pallet

19 lbs Per Case

812 lbs Per Pallet

Pallet Dimensions: 48" x 40" x 95"

Box Size: 14" x 17" x 14"

87 mm Coverall Lid - Bulk Pack:

2,100 Per Case – 50,400 Per Pallet

4 Cases Per Layer

6 Layers Per Skid

24 Cases Per Pallet

29 lbs Per Case

811 lbs Per Pallet

Pallet Dimensions: 40" x 48" x 95"

Box Size: 25" x 20" x 15"



8 OZ / 237 ML CUP

8 OZ SQUAT CUP ◀

CUP PROPERTIES:

Maximum Fill Volume: 8.8 oz / 260 ml
 Practical Volume: 8 oz / 237 ml
 Stack Height: 12.2" / 25 Cups
 Sidewall Material: 18 PT, Polycoated 2 Sides, 1/2 x 3/4 mil
 Bottom Material: 12.5 PT, Polycoated 2 Sides, 1/2 x 3/4 mil

PACKAGING CONFIGURATIONS:

8 oz Cups - 500 Pack:

500 Per Case - 18,000 Per Pallet
 6 Cases Per Layer
 6 Layers Per Pallet
 36 Cases Per Pallet
 11.7 lbs Per Case
 12 lbs Per Pallet
 Pallet Dimensions: 48" x 40" x 88"
 Box Size: 20" x 16" x 14"

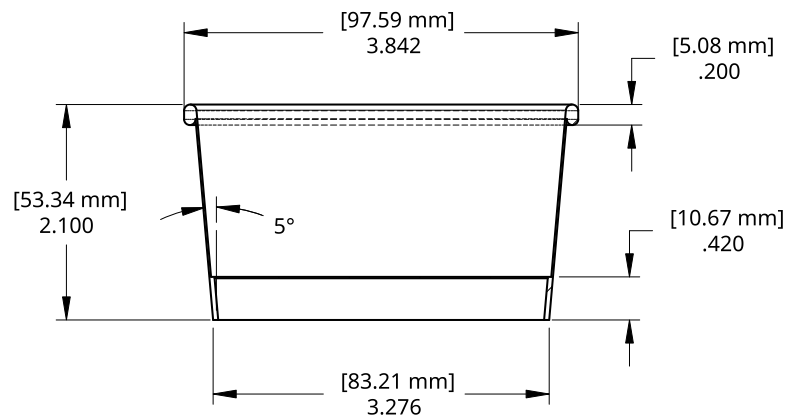



12 OZ / 355 ML CUP

12 OZ CUP ◀

CUP PROPERTIES:

Maximum Fill Volume: 12.60 oz / 373 ml

Practical Volume: 12 oz / 355 ml

Stack Height: 21.8" / 50 Cups

Sidewall Material: 16 PT, Polycoated 2 Sides, 1/2 x 3/4 mil

Bottom Material: 12.5 PT, Polycoated 2 Sides, 1/2 x 3/4 mil

PACKAGING CONFIGURATIONS:

12 oz Cups:

1,000 Per Case – 32,000 Per Pallet

8 Cases Per Layer

4 Layers Per Pallet

32 Cases Per Pallet

26 lbs Per Case

867 lbs Per Pallet

Pallet Dimensions: 48" x 40" x 96"

Box Size: 17" x 14" x 23"

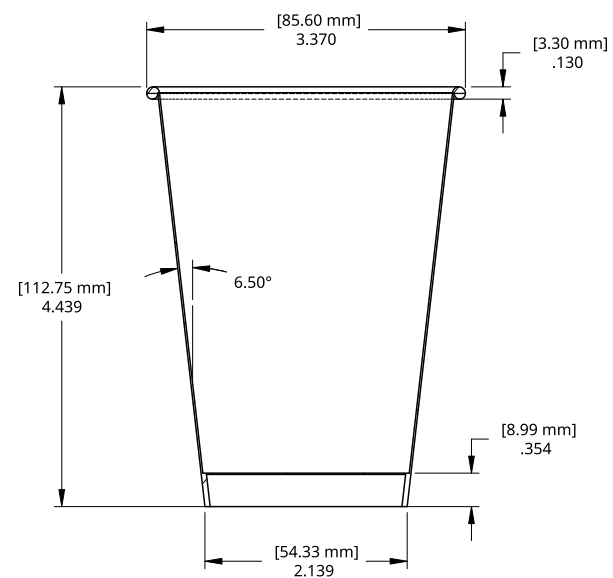

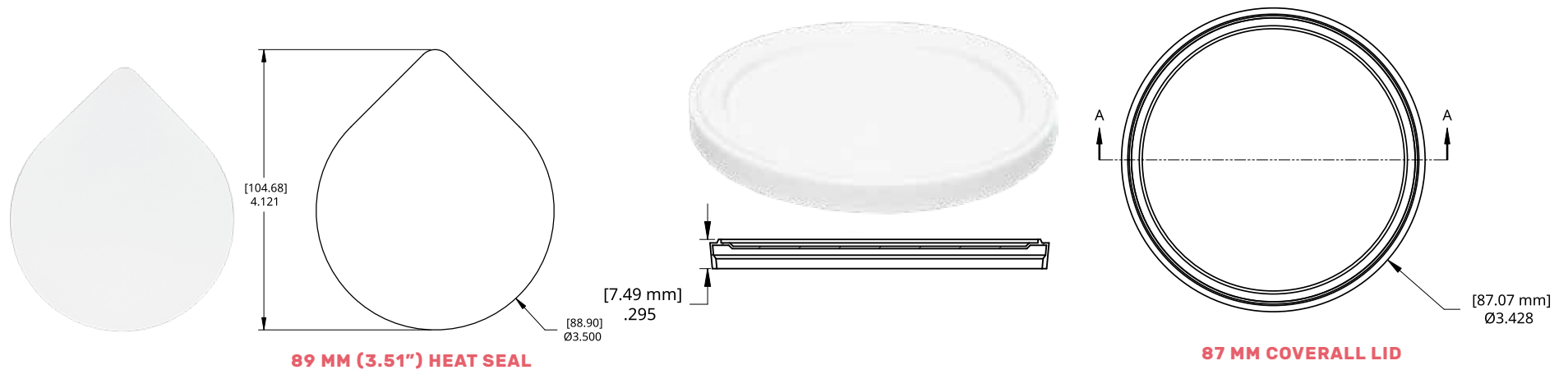

89 MM (3.51") HEAT SEAL

87 MM COVERALL LID

12 OZ CUP ◀

89 MM HEAT SEAL PROPERTIES:

Paper Material: 70# Multiflex Gloss

PACKAGING CONFIGURATIONS:

89 mm (3.51") Teardrop Heat Seal Lid

9,000 Per Case – 576,000 Per Pallet

16 Cases Per Layer

4 Layers Per Pallet

64 Cases Per Pallet

17 lbs Per Case

1123 lbs Per Pallet

Pallet Dimensions: 48" x 40" x 42"

Box Size: 12" x 8" x 9"

87 MM COVERALL LID PROPERTIES:

Plastic Material: LLDPE

PACKAGING CONFIGURATIONS:

87 mm Coverall Lid - Standard Pack Sleeved*:

1,000 Per Case – 42,000 Per Pallet

7 Cases Per Layer

6 Layers Per Skid

42 Cases Per Pallet

19 lbs Per Case

812 lbs Per Pallet

Pallet Dimensions: 48" x 40" x 95"

Box Size: 14" x 17" x 14"

87 mm Coverall Lid - Bulk Pack:

2,100 Per Case – 50,400 Per Pallet

4 Cases Per Layer

6 Layers Per Skid

24 Cases Per Pallet

29 lbs Per Case

731 lbs Per Pallet

Pallet Dimensions: 40" x 48" x 95"

Box Size: 25" x 20" x 15"



12 OZ / 355 ML CUP

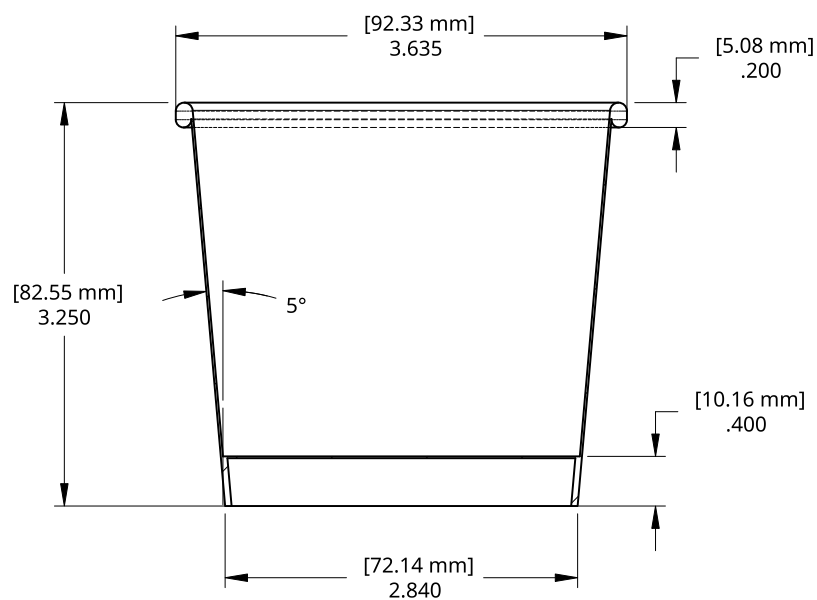

12 OZ SQUAT ◀

CUP PROPERTIES:

Maximum Fill Volume: 14 oz / 414 ml

Practical Volume: 12 oz / 355 ml

Stack Height: 22.9" / 50 Cups

Sidewall Material: 16 PT, Polycoated 2 Sides, 1/2 x 3/4 mil

Bottom Material: 12.5 PT, Polycoated 2 Sides, 1/2 x 3/4 mil

PACKAGING CONFIGURATIONS:

12 oz Cups:

1,000 Per Case – 24,000 Per Pallet

6 Cases Per Layer

4 Layers Per Pallet

24 Cases Per Pallet

27 lbs Per Case

683 lbs Per Pallet

Pallet Dimensions: 48" x 40" x 70"

Box Size: 19" x 15" x 24"



SPIRAL WOUND LID

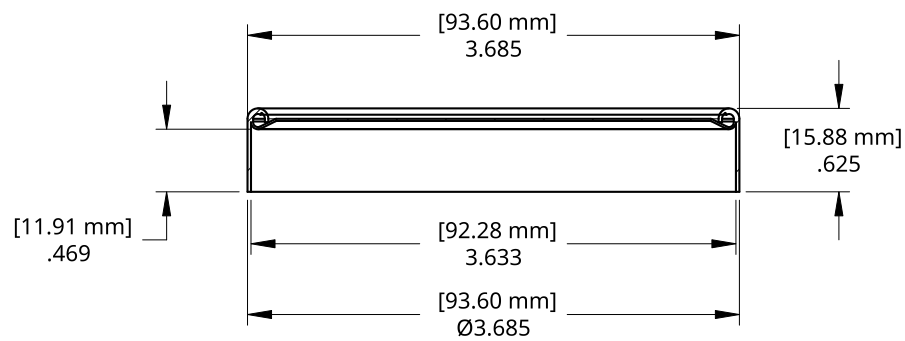

12 OZ SQUAT ◀

SPIRAL WOUND LID PROPERTIES:

Disc Material: 14PT, Polycoated 1 Side, 1/2 mil Matte
 Skirt Material: 3 Ply Paperboard, 1/2 mil Matte 11.3Pt,

PACKAGING CONFIGURATIONS:

Spiral Wound Lid:

1,000 Per Case - 12,000 Per Pallet
 3 Cases Per Layer
 4 Layers Per Pallet
 12 Cases Per Pallet
 19 lbs Per Case
 263 lbs Per Pallet
 Pallet Dimensions: 48" x 40" x 85"
 Box Size: 32" x 15" x 19"



12 OZ SHORT SQUAT CUP ◀

CUP PROPERTIES:

Maximum Fill Volume: 12.8 oz / 379 ml
 Practical Volume: 12.5 oz / 370 ml
 Stack Height: 13.1" / 25 Cups
 Sidewall Material: 18 PT, Polycoated 2 Sides, 1/2 x 3/4 mil
 Bottom Material: 13.5 PT, Polycoated 2 Sides, 1/2 x 3/4 mil

PACKAGING CONFIGURATIONS:

12 oz Cups - 500 Pack:

500 Per Case - 18,000 Per Pallet
 6 Cases Per Layer
 6 Layers Per Pallet
 36 Cases Per Pallet
 16 lbs Per Case
 611 lbs Per Pallet
 Pallet Dimensions: 48" x 48" x 90"
 Box Size: 20" x 16" x 14"

12.5 OZ / 370 ML CUP

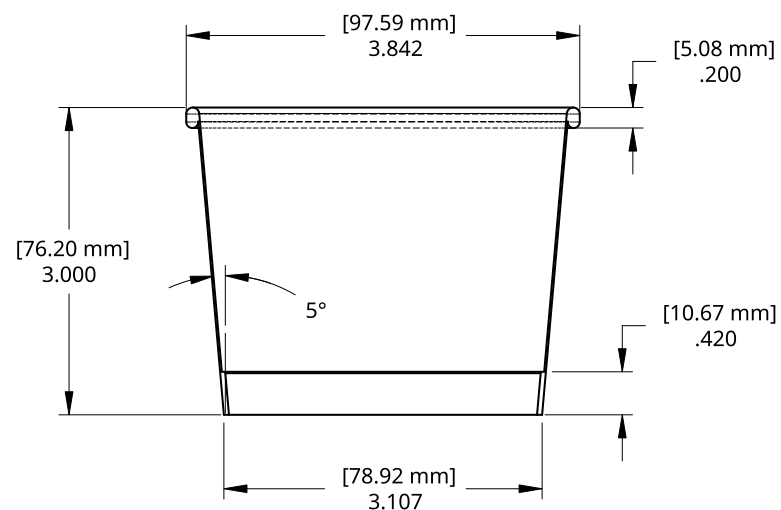



14 OZ / 424 ML CUP

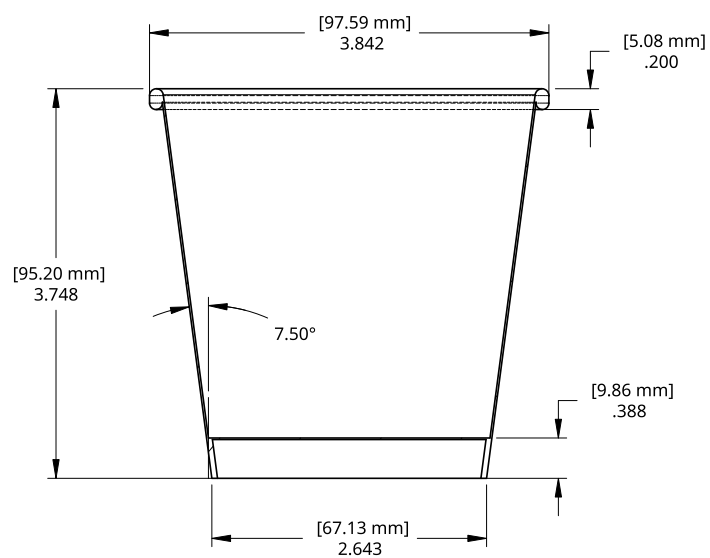

14 OZ CUP ◀

CUP PROPERTIES:

Maximum Fill Volume: 14.6 oz / 431 ml
 Practical Volume: 14 oz / 424 ml
 Stack Height: 22.8" / 50 Cups
 Sidewall Material: 16 PT, Polycoated 2 Sides, 1/2 x 1/2 mil
 Bottom Material: 13.5 PT, Polycoated 2 Sides, 1/2 x 1/2 mil

PACKAGING CONFIGURATIONS:

14 oz Cups:

1,000 Per Case -24,000 Per Pallet
 20 Stacks of 50 cups each
 6 Cases Per Layer
 4 Layers Per Pallet
 24 Cases Per Pallet
 28 lbs Per Case
 707 lbs Per Pallet
 Pallet Dimensions: 48" x 40" x 99"
 Box Size: 19" x 16" x 24"

16 OZ CUP ◀



16 OZ / 473 ML CUP

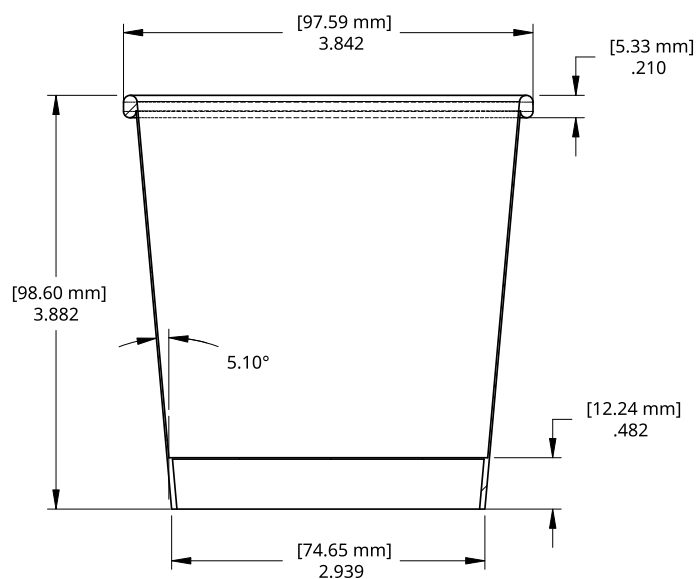

CUP PROPERTIES:

Maximum Fill Volume: 16.1 oz / 476 ml
 Practical Volume: 16 oz / 473 ml
 Stack Height: 27.5" / 50 Cups
 Sidewall Material: 16 PT, Polycoated 2 Sides, 1/2 x 1/2 mil
 Bottom Material: 13.5 PT, Polycoated 2 Sides, 1/2 x 1/2 mil

PACKAGING CONFIGURATIONS:

16 oz Cups:

1,000 Per Case - 18,000 Per Pallet
 20 Stacks of 50 cups each
 6 Cases Per Layer
 3 Layers Per Pallet
 18 Cases Per Pallet
 33 lbs Per Case
 629 lbs Per Pallet
 Pallet Dimensions: 48" x 40" x 88"
 Box Size: 20" x 16" x 28"

16 oz Cups - Food Service Pack:

500 Per Case - 15,000 Per Pallet
 20 Stacks of 25 cups each
 Each stack packed in a poly sleeve and taped closed
 6 Cases Per Layer
 5 Layers Per Pallet
 30 Cases Per Pallet
 19 lbs Per Case
 605 lbs Per Pallet
 Pallet Dimensions: 40" x 48" x 86"
 Box Size: 20" x 16" x 16"

16 oz Cups - Food Service Combo Pack:

250 each cups and lids Per Case - 5,000 each Per Pallet
 10 Stacks of 25 cups and lids
 4 Cases Per Layer
 5 Layers Per Pallet
 20 Cases Per Pallet
 15 lbs Per Case
 335 lbs Per Pallet
 Pallet Dimensions: 48" x 40" x 86"
 Box Size: 20" x 16" x 16"



16.91 OZ / 500 ML CUP

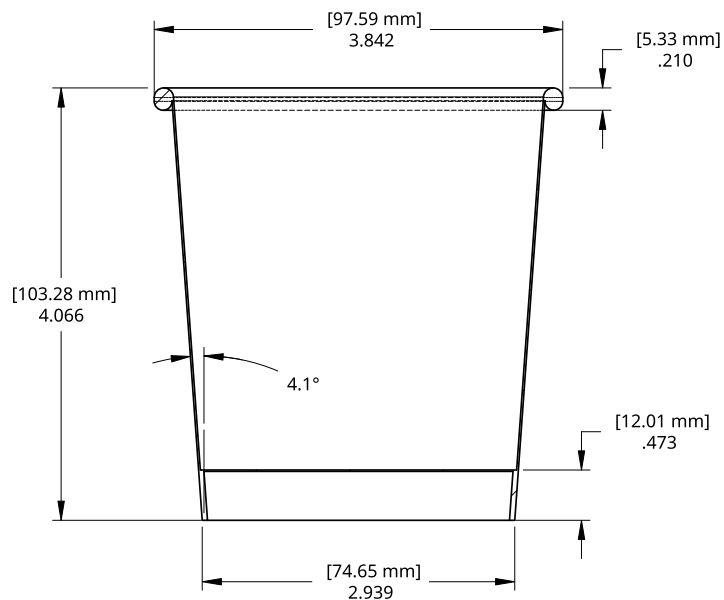

500 ML CUP ◀

CUP PROPERTIES:

Maximum Fill Volume: 17.2 oz / 509 ml
 Practical Volume: 16.91 oz / 500 ml
 Stack Height: 27.2" / 50 Cups
 Sidewall Material: 16 PT, Polycoated 2 Sides, 1/2 x 1/2 mil
 Bottom Material: 13.5 PT, Polycoated 2 Sides, 1/2 x 1/2 mill

PACKAGING CONFIGURATIONS:

500 ml Cups:

1,000 Per Case – 18,000 Per Pallet
 20 Stacks of 50 cups each
 6 Cases Per Layer
 3 Layers Per Pallet
 18 Cases Per Pallet
 33 lbs Per Case
 629 lbs Per Pallet
 Pallet Dimensions: 48" x 40" x 88"
 Box Size: 20" x 16" x 28"

500 ml Cups - Food Service Pack:

500 Per Case – 15,000 Per Pallet
 20 Stacks of 25 cups each
 Each stack packed in a poly sleeve and taped closed
 6 Cases Per Layer
 5 Layers Per Pallet
 30 Cases Per Pallet
 19 lbs Per Case
 605 lbs Per Pallet
 Pallet Dimensions: 41" x 48" x 86"
 Box Size: 20" x 16" x 16"

8, 12 SHORT SQUAT, 14, 16 OZ & 500 ML LIDS ◀

SPIRAL WOUND LID PROPERTIES:

Disc Material: 14 PT, Polycoated 1 Side, 1/2 mil Matte

Tube Material: 3 Ply Paperboard

PACKAGING CONFIGURATIONS:

Spiral Wound Lid – Bulk Packed:

1,000 Per Case – 16,000 Per Pallet

4 Cases Per Layer

4 Layers Per Pallet

16 Cases Per Pallet

18 lbs Per Case

323 lbs Per Pallet

Pallet Dimensions: 48" x 40" x 102"

Box Size: 18" x 20" x 24"

Spiral Wound Lid – Wrapped:

1,000 Per Case – 12,000 Per Pallet

20 Stacks of 50 lids Per stack

3 Cases Per Layer

4 Layers Per Pallet

12 Cases Per Pallet

19 lbs Per Case

263 lbs Per Pallet

Pallet Dimensions: 40" x 48" x 85"

Box Size: 32" x 16" x 20"

Spiral Wound Lid – Food Service Pack:

500 Per Case – 12,000 Per Pallet

20 Stacks of 25 lids

4 Cases Per Layer

6 Layers Per Pallet

24 Cases Per Pallet

9 lbs Per Case

251 lbs Per Pallet

Pallet Dimensions: 41" x 48" x 87"

Box Size: 20" x 17" x 14"

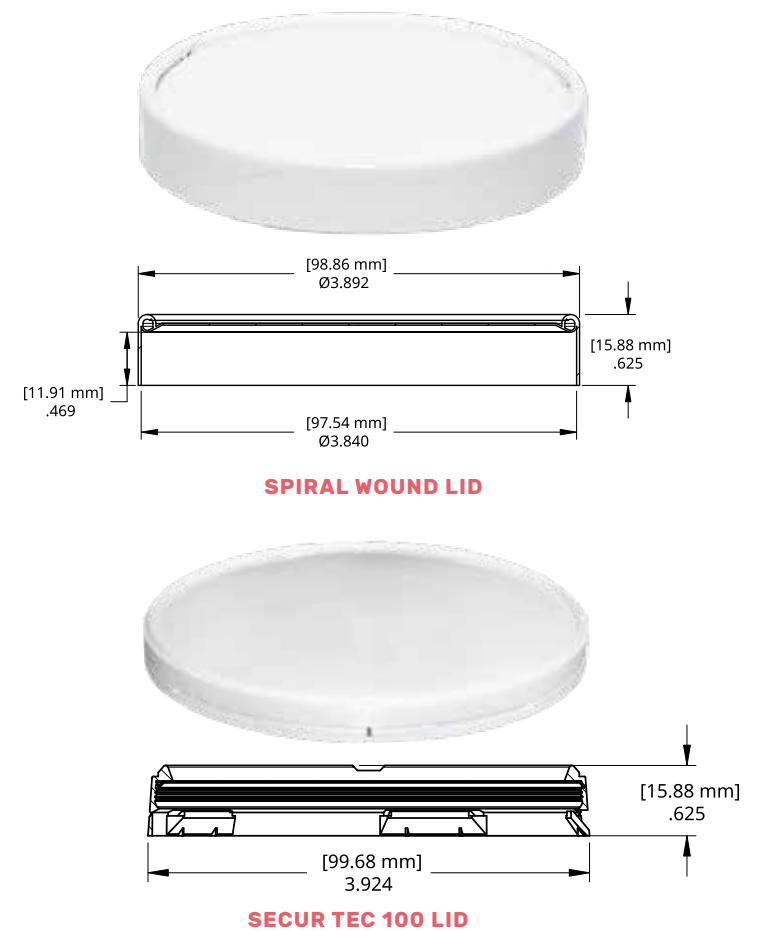

SECUR TEC 100 LID PROPERTIES:

Plastic Material: LLDPE

Paper Material: 16 PT, Polycoated 2 Sides, 1/2 x 3/4 mil

PACKAGING CONFIGURATIONS:

Secur Tec 100 Pint Lid:

600 Per Case – 18,000 Per Pallet

20 Stacks of 30 Lids Each

6 Cases Per Layer

5 Layers Per Skid

30 Cases Per Pallet

14 lbs Per Case

455 lbs Per Pallet

Pallet Dimensions: 40" x 48" x 85"

Box Size: 16" x 20" x 16"



24 OZ / 710 ML CUP

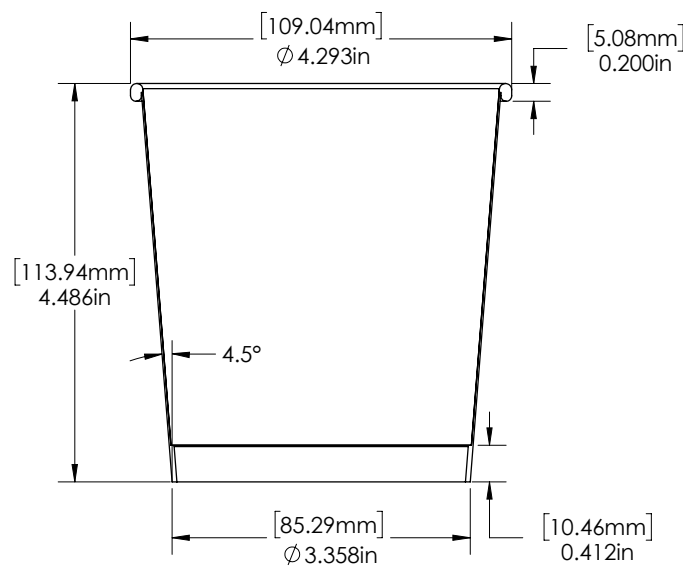

24 OZ CUP ◀

CUP PROPERTIES:

Maximum Fill Volume: 24.4 oz / 721 ml

Practical Volume: 24 oz / 710 ml

Stack Height: 14.4" / 25 Cups

Sidewall Material: 18 PT, Polycoated 2 Sides, 1/2 x 3/4 mil

Bottom Material: 13.5 PT, Polycoated 2 Sides, 1/2 x 3/4 mil

PACKAGING CONFIGURATIONS:

24 oz Cups:

500 Per Case -10,000 Per Pallet

4 Cases Per Layer

5 Layers Per Pallet

20 Cases Per Pallet

22 lbs Per Case

475 lbs Per Pallet

Pallet Dimensions: 40" x 48" x 80"

Box Size: 22" x 18" x 15"



SPIRAL WOUND LID

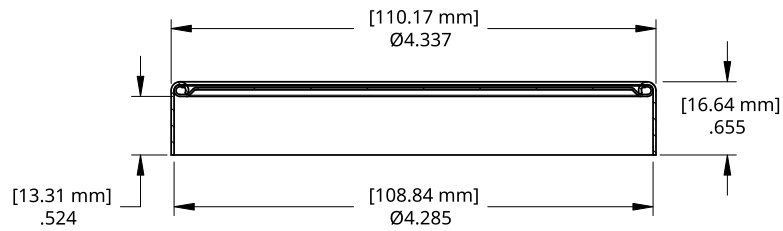

24 OZ CUP LID ◀

SPIRAL WOUND LID PROPERTIES:

Disc Material: 16 PT, Polycoated 1 side, 1/2 mil matte
 Tube Material: 3 ply Paperboard

PACKAGING CONFIGURATIONS:

Spiral Wound Lid - Bulk Packed:

500 Per Case - 10,000 Per Pallet
 4 Cases Per Layer
 5 Layers Per Pallet
 20 Cases Per Pallet
 8 lbs Per Case
 195 lbs Per Pallet
 Pallet Dimensions: 40" x 48" x 85"
 Box Size: 24" x 20" x 16"



32 OZ / 946 ML CUP

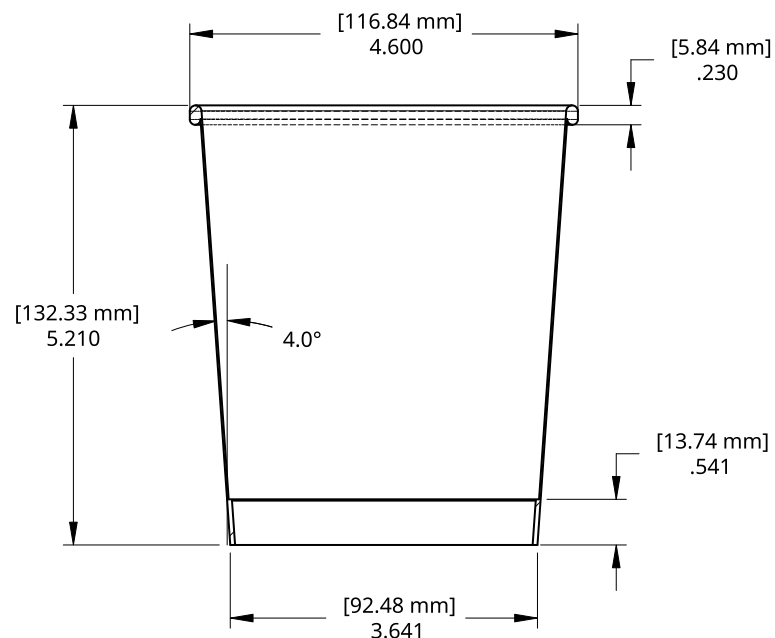

QUART CUP ◀

CUP PROPERTIES:

Maximum Fill Volume: 32.66 oz / 962 ml
 Practical Volume: 32 oz / 946 ml
 Stack Height: 18.2" / 25 Cups
 Sidewall Material: 18 PT, Polycoated 2 Sides, 1/2 x 3/4 mil
 Bottom Material: 13.5 PT, Polycoated 2 Sides, 1/2 x 3/4 mil

PACKAGING CONFIGURATIONS:

Quart Cups:

500 Per Case – 8,000 Per Pallet
 4 Cases Per Layer
 4 Layers Per Pallet
 16 Cases Per Pallet
 29 lbs Per Case
 499 lbs Per Pallet
 Pallet Dimensions: 48" x 40" x 85"
 Box Size: 24" x 19" x 20"

Quart Cups - Food Service Pack:

500 Per Case – 8,000 Per Pallet
 20 Stacks of 25 cups
 Each stack packed in a poly sleeve and taped closed
 16 Cases Per Pallet
 29 lbs Per Case
 499 lbs Per Pallet
 Pallet Dimensions: 48" x 40" x 85"
 Box Size: 24" x 19" x 20"

Quart Cups - Food Service Combo Pack:

250 each cups and lids Per Case – 4,000 each Per Pallet
 10 Stacks of 25 cups and 25 lids
 Each stack packed in a poly sleeve and taped closed
 16 Cases Per Pallet
 21 lbs Per Case
 371 lbs Per Pallet
 Pallet Dimensions: 40" x 48" x 85"
 Box Size: 24" x 19" x 20"



33.81 OZ / 1000 ML CUP

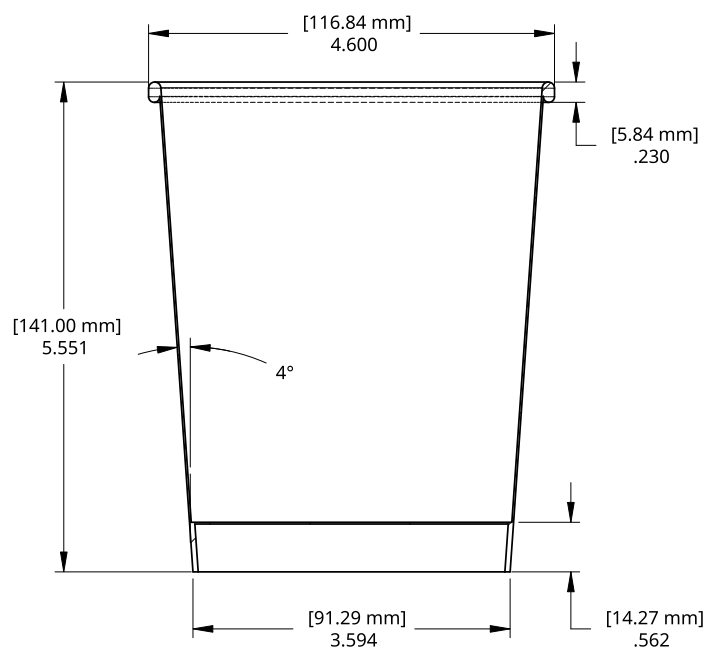

LITRE CUP ◀

CUP PROPERTIES:

Maximum Fill Volume: 34.5 oz / 1021 ml
 Practical Volume: 33.8 oz / 1000 ml
 Stack Height: 19" / 25 Cups
 Sidewall Material: 18 PT, Polycoated 2 Sides, 1/2 x 3/4 mil
 Bottom Material: 13.5 PT, Polycoated 2 Sides, 1/2 x 3/4 mil

PACKAGING CONFIGURATIONS:

Litre Cups:

500 Per Case – 8,000 Per Pallet
 4 Cases Per Layer
 4 Layers Per Pallet
 16 Cases Per Pallet
 29 lbs Per Case
 499 lbs Per Pallet
 Pallet Dimensions: 48" x 40" x 85"
 Box Size: 24" x 19" x 20"

Litre Cups - Food Service Pack:

500 Per Case – 8,000 Per Pallet
 20 Stacks of 25 cups
 Each stack packed in a poly sleeve and taped closed
 16 Cases Per Pallet
 29 lbs Per Case
 499 lbs Per Pallet
 Pallet Dimensions: 48" x 40" x 85"
 Box Size: 24" x 19" x 20"

Litre Cups - Food Service Combo Pack:

250 each cups and lids Per Case – 4,000 each Per Pallet
 10 Stacks of 25 cups and 25 lids
 Each stack packed in a poly sleeve and taped closed
 16 Cases Per Pallet
 21 lbs Per Case
 371 lbs Per Pallet
 Pallet Dimensions: 40" x 48" x 85"
 Box Size: 24" x 19" x 20"

LITRE & QUART CUP LIDS ◀

SPIRAL WOUND LID PROPERTIES:

Disc Material: 16 PT, Polycoated 1 Side, 1/2 mil matte

Tube Material: 3ply Paperboard

PACKAGING CONFIGURATIONS:

Spiral Wound Lid – Bulk Packed:

750 Per Case – 12,000 Per Pallet

4 Cases Per Layer

4 Layers Per Pallet

16 Cases Per Pallet

18 lbs Per Case

323 lbs Per Pallet

Pallet Dimensions: 40" x 51" x 93"

Box Size: 24" x 17" x 22"

Spiral Wound Lid – Food Service Pack:

500 lids Per Case – 8,000 Per Pallet

20 Stacks of 25 lids

4 Cases Per Layer

4 Layers Per Pallet

16 Cases Per Pallet

13 lbs Per Case

243 lbs Per Pallet

Pallet Dimensions: 40" x 48" x 67"

Box Size: 24" x 20" x 16"

Spiral Wound Lid – Wrapped:

1,000 Per Case – 9,000 Per Pallet

20 Stacks of 50 lids Per stack

3 Cases Per Layer

3 Layers Per Pallet

9 Cases Per Pallet

26 lbs Per Case

269 lbs Per Pallet

Pallet Dimensions: 40" x 56" x 78"

Box Size: 36" x 19" x 24"

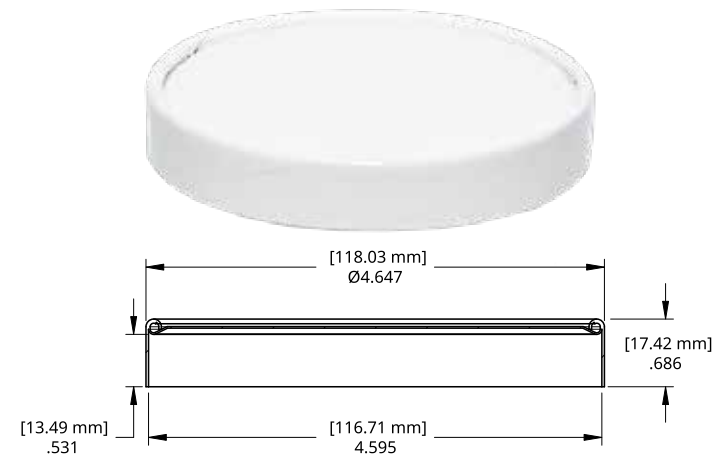

SPIRAL WOUND LID

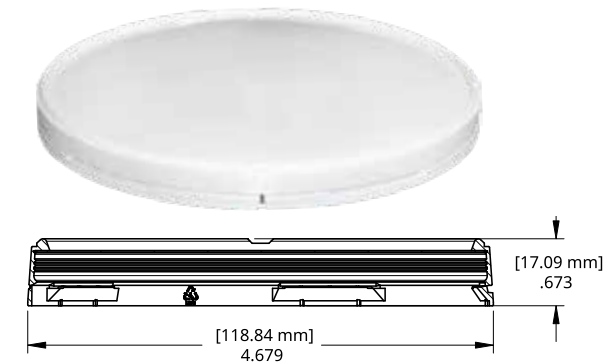

SECUR TEC 125 LID

SECUR TEC 125 LID PROPERTIES:

Plastic Material: LLDPE

Paper Material: 16 PT, Polycoated 2 Sides, 1/2 x 1/2 mil

PACKAGING CONFIGURATIONS:

Secur Tec 125 Lid:

600 Per Case – 9,600 Per Pallet

20 Stacks of 30 Lids Each

4 Cases Per Layer

4 Layers Per Skid

16 Cases Per Pallet

18 lbs Per Case

323 lbs Per Pallet

Pallet Dimensions: 40" x 48" x 82"

Box Size: 24" x 19" x 19"



48 OZ / 1.42 L CUP

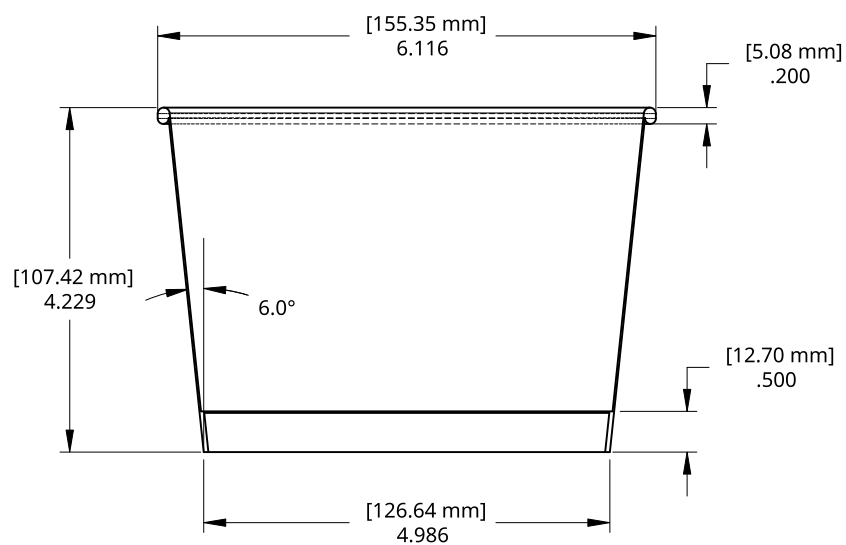

48 OZ CUP TALL ◀

CUP PROPERTIES:

Maximum Fill Volume: 48.2 oz / 1.4 L

Practical Volume: 48 oz / 1.4 L

Stack Height: 28.7" / 50 Cups

Sidewall Material: 18 PT, Polycoated 2 Sides, 1/2 x 3/4 mil

Bottom Material: 18 PT, Polycoated 2 Sides, 1/2 x 3/4 mil

PACKAGING CONFIGURATIONS:

48 oz Cups:

300 Per Case – 6,300 Per Pallet

7 Cases Per Layer

3 Layers Per Pallet

21 Cases Per Pallet

23 lbs Per Case

518 lbs Per Pallet

Pallet Dimensions: 48" x 40" x 94"

Box Size: 13" x 19" x 29"



56 OZ / 1.65 L CUP

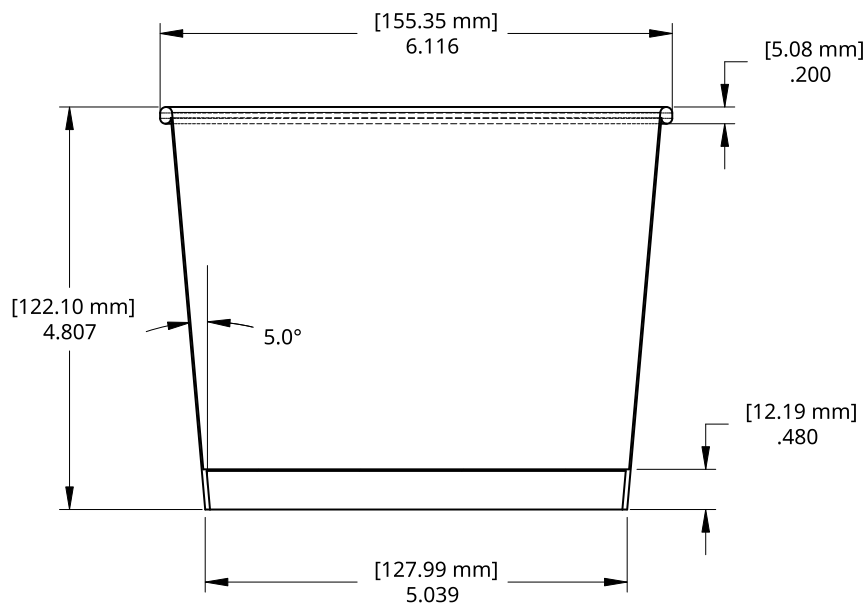

56 OZ CUP TALL ◀

CUP PROPERTIES:

Maximum Fill Volume: 56.2 oz / 1.7 L

Practical Volume: 56 oz / 1.7 L

Stack Height: 28.3" / 50 Cups

Sidewall Material: 18 PT, Polycoated 2 Sides, 1/2 x 3/4 mil

Bottom Material: 18 PT, Polycoated 2 Sides, 1/2 x 3/4 mil

PACKAGING CONFIGURATIONS:

56 oz Cups:

300 Per Case – 6,300 Per Pallet

7 Cases Per Layer

3 Layers Per Pallet

21 Cases Per Pallet

23 lbs Per Case

518 lbs Per Pallet

Pallet Dimensions: 48" x 40" x 94"

Box Size: 13" x 19" x 29"



67.63 OZ / 2 L CUP

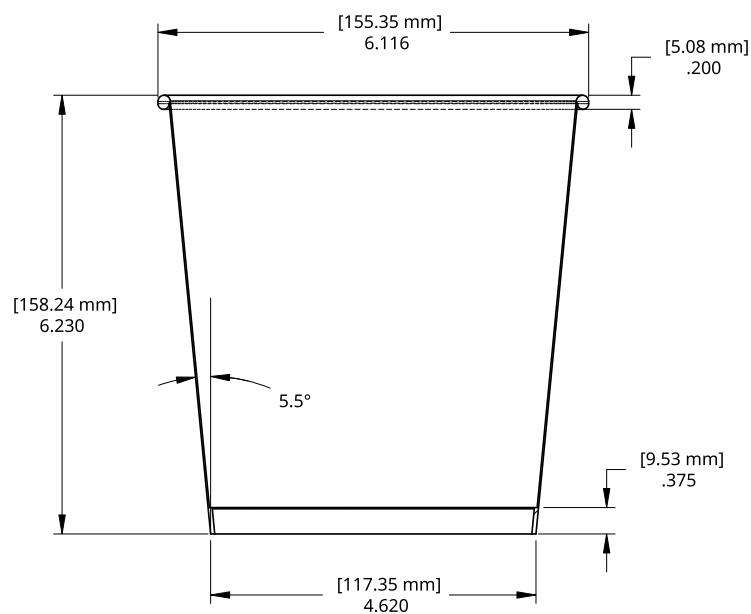

2 LITRE CUP ◀

CUP PROPERTIES:

Maximum Fill Volume: 68.8 oz / 2.0 L

Practical Volume: 67.4 oz / 2.0 L

Stack Height: 24.6" / 50 Cups

Sidewall Material: 23 PT, Polycoated 2 Sides, 1/2 x 3/4 mil

Bottom Material: 18 PT, Polycoated 2 Sides, 1/2 x 3/4 mil

PACKAGING CONFIGURATIONS:

2 Litre Cups:

300 Per Case – 6,300 Per Pallet

7 Cases Per Layer

3 Layers Per Pallet

21 Cases Per Pallet

22 lbs Per Case

497 lbs Per Pallet

Pallet Dimensions: 40" x 48" x 83"

Box Size: 19" x 13" x 26"

48, 56 OZ & 2 LITRE CUP LIDS ◀

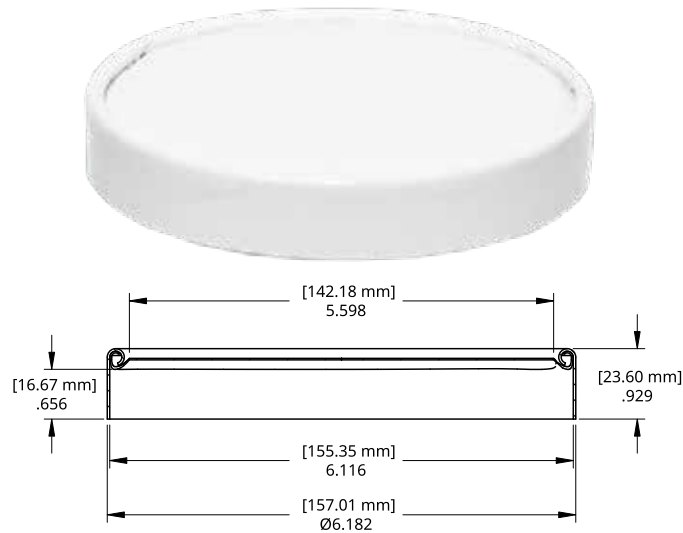

SPIRAL WOUND LID

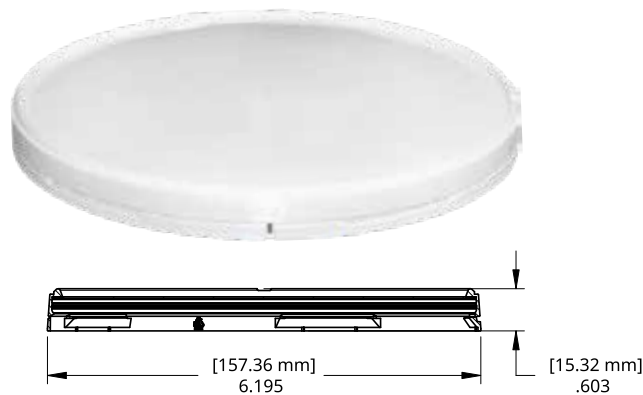

SECURE TEC 160 LID

SPIRAL WOUND LID PROPERTIES:

Disc Material: 16PT, Polycoated 1 Side, 1/2 mil
Tube Material: 3 ply Paperboard

PACKAGING CONFIGURATIONS:

Spiral Wound Lid:

300 Per Case – 6,000 Per Pallet
4 Cases Per Layer
5 Layers Per Pallet
20 Cases Per Pallet
16 lbs Per Case
355 lbs Per Pallet
Pallet Dimensions: 40" x 50" x 102"
Box Size: 25" x 19" x 19"

SECUR TEC 160 LID PROPERTIES:

Plastic Material: LLDPE
Paper Material: 18 PT, Polycoated 2 Sides, 1/2 x 1/2 mil

PACKAGING CONFIGURATIONS:

Secur Tec 160 Lid:

150 Per Case – 6,300 Per Pallet
7 Cases Per Layer
6 Layers Per Pallet
42 Cases Per Pallet
12 lbs Per Case
539 lbs Per Pallet
Pallet Dimensions: 48" x 40" x 84"
Box Size: 19" x 14" x 13"



64 OZ / 1.89 L CUP

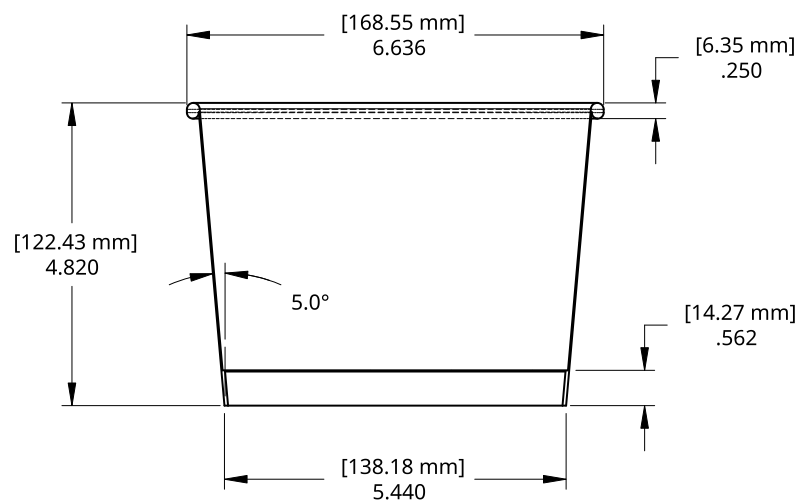

64 OZ CUP TALL ◀

CUP PROPERTIES:

Maximum Fill Volume: 64 oz / 1.9 L

Practical Volume: 64 oz / 1.9 L

Stack Height: 18.31" / 25 Cups

Sidewall Material: 18 PT, Polycoated 2 Sides, 1/2 x 3/4 mil

Bottom Material: 18 PT, Polycoated 2 Sides, 1/2 x 3/4 mil

PACKAGING CONFIGURATIONS:

64 oz Cups:

300 Per Case – 3,600 Per Pallet

3 Cases Per Layer

4 Layers Per Pallet

12 Cases Per Pallet

23.4 lbs Per Case

316 lbs Per Pallet

Pallet Dimensions: 48" x 40" x 81"

Box Size: 28" x 20" x 19"

64 oz Cups - Food Service:

252 Per Case – 3,024 Per Pallet

3 Cases Per Layer

4 Layers Per Pallet

12 Cases Per Pallet

23 lbs Per Case

311 lbs Per Pallet

Pallet Dimensions: 48" x 40" x 73"

Box Size: 28" x 20" x 17"

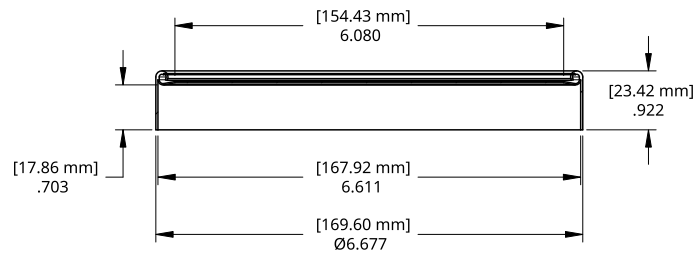

SPIRAL WOUND LID

64 OZ CUP LID ◀

SPIRAL WOUND LID PROPERTIES:

Disc Material: 20PT, Polycoated 1 Side, 1/2 mil
 Tube Material: 3 ply Paperboard

PACKAGING CONFIGURATIONS:

Spiral Wound Lid:

252 Per Case - 3,024 Per Pallet
 3 Cases Per Layer
 4 Layers Per Pallet
 12 Cases Per Pallet
 16 lbs Per Case
 227 lbs Per Pallet
 Pallet Dimensions: 48" x 40" x 88"
 Box Size: 30" x 19" x 21"



48 OZ CUP NON ROUND ◀

CUP PROPERTIES:

Maximum Fill Volume: 48.41 oz / 1.43 L
 Practical Volume: 48 oz / 1.42 L
 Stack Height: 23.4" / 50 Cups
 Sidewall Material: 18 PT, Polycoated 2 Sides, 1/2 x 3/4 mil
 Bottom Material: 18 PT, Polycoated 2 Sides, 1/2 x 3/4 mil

48 OZ / 1419.5 ML CUP

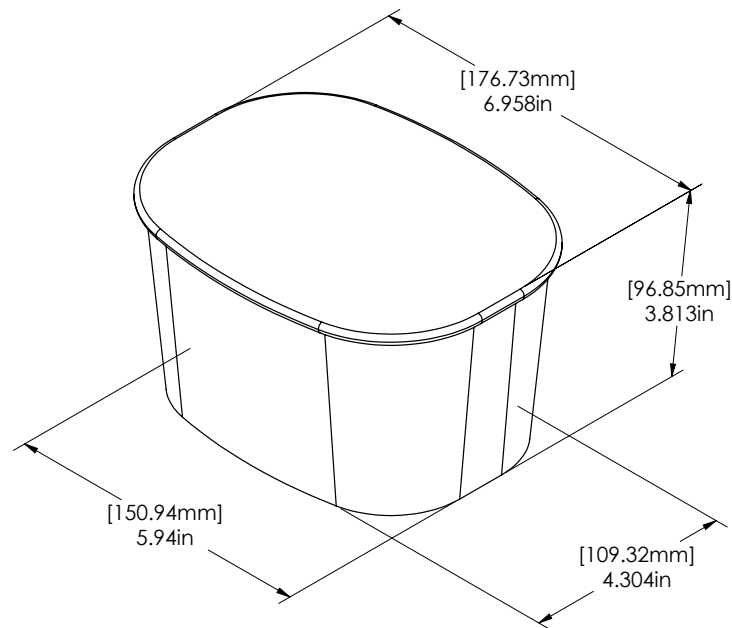

PACKAGING CONFIGURATIONS:

48 oz Cups:

400 Per Case – 7,200 Per Pallet
 6 Cases Per Layer
 3 Layers Per Pallet
 18 Cases Per Pallet
 29 lbs Per Case
 557 lbs Per Pallet
 Pallet Dimensions: 48" x 40" x 82"
 Box Size: 19" x 16" x 26"



56 OZ / 1.65 ML CUP

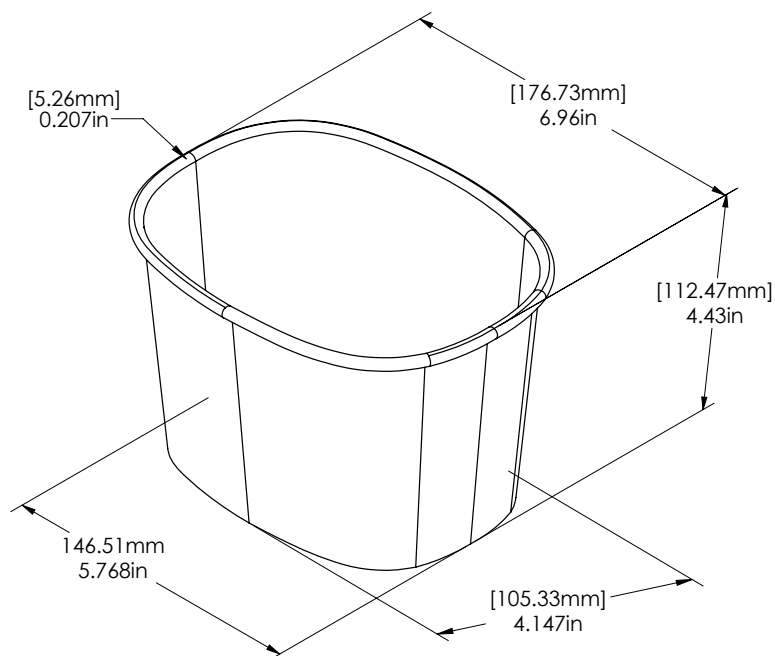

56 OZ CUP NON ROUND ◀

CUP PROPERTIES:

Maximum Fill Volume: 56.02 oz / 1.66 L
 Practical Volume: 56 oz / 1.66 L
 Stack Height: 24" / 50 Cups
 Sidewall Material: 18 PT, Polycoated 2 Sides, 1/2 x 3/4 mil
 Bottom Material: 18PT, Polycoated 2 Sides, 1/2 x 3/4 mil

PACKAGING CONFIGURATIONS:

56 oz Cups:

400 Per Case – 7,200 Per Pallet
 6 Cases Per Layer
 3 Layers Per Pallet
 18 Cases Per Pallet
 29 lbs Per Case
 557 lbs Per Pallet
 Pallet Dimensions: 40" x 48" x 82"
 Box Size: 19" x 16" x 26"



64 OZ / 1.89 L CUP

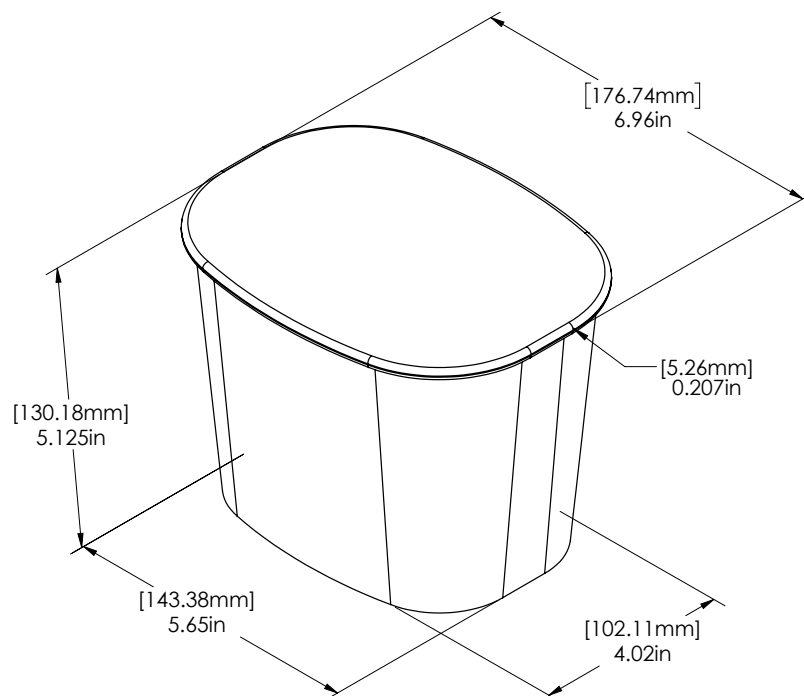

64 OZ CUP NON ROUND ◀

CUP PROPERTIES:

Maximum Fill Volume: 64.2 oz / 1.90 L

Practical Volume: 64 oz / 1.89 L

Stack Height: 24.7" / 50 Cups

Sidewall Material: 20 PT, Polycoated 2 Sides, 1/2 x 3/4 mil

Bottom Material: 18 PT, Polycoated 2 Sides, 1/2 x 3/4 mil

PACKAGING CONFIGURATIONS:

64 oz Cups:

400 Per Case – 7,200 Per Pallet

6 Cases Per Layer

3 Layers Per Pallet

18 Cases Per Pallet

29 lbs Per Case

557 lbs Per Pallet

Pallet Dimensions: 40" x 48" x 82"

Box Size: 19" x 16" x 26"

NON ROUND PAPER LID

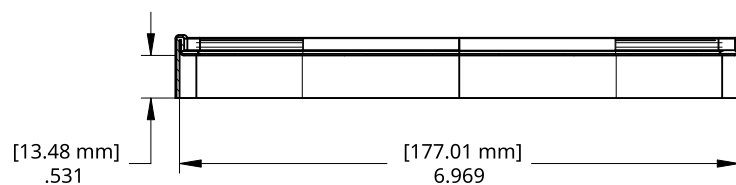
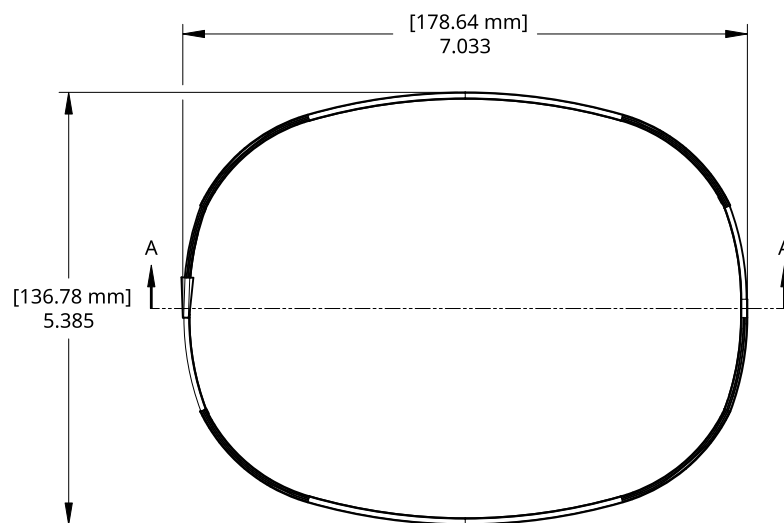

48, 56 & 64 OZ CUP NON ROUND LIDS ◀

PAPER WRAPPED LID PROPERTIES:

Disc Material:

18 PT, Polycoated 2 Sides, 1/2 x 1/2 PT

Skirt Material: 28 PT, Polycoated 1 Side, 1/2 mil

PACKAGING CONFIGURATIONS

Paper Wrapped Lid:

300 Per Case – 4,800 Per Pallet

4 Cases Per Layer

4 Layers Per Pallet

16 Cases Per Pallet

18 lbs Per Case

323 lbs Per Pallet

Pallet Dimensions: 40" x 51" x 92"

Box Size: 21.875" x 21.875" x 19.125"

SECUR TEC 176 LID

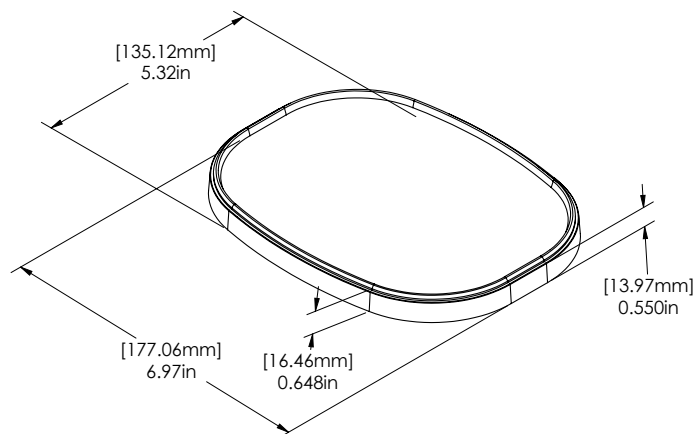

SECUR TEC 176 LID PROPERTIES:

Disc Material:

18 PT, Polycoated 2 sides 1/2 x 1/2 mil

Skirt Material: LLDPE

PACKAGING CONFIGURATIONS

Secur Tec 176 Lid:

300 Per Case – 5,400 Per Pallet

10 Stacks of 30 Lids Each

3 Cases Per Layer

6 Layers Per Skid

18 Cases Per Pallet

18 lbs Per Case

359 lbs Per Pallet

Pallet Dimensions: 48" x 40" x 96"

Box Size: 27" x 17" x 15"

NON ROUND COMPOSITE LID

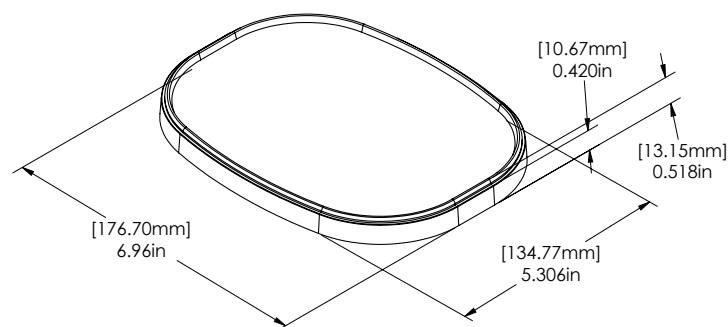

NON ROUND COMPOSITE LID PROPERTIES:

Disc Material:

18 PT, Polycoated 2 sides 1/2 x 1/2 mil

Skirt Material: LLDPE

PACKAGING CONFIGURATIONS

Non Round Composite Lid:

400 Per Case – 7,200 Per Pallet

3 Cases Per Layer

6 Layers Per Pallet

18 Cases Per Pallet

19 lbs Per Case

377 lbs Per Pallet

Pallet Dimensions: 48" x 40" x 95"

Box Size: 28" x 18" x 15"

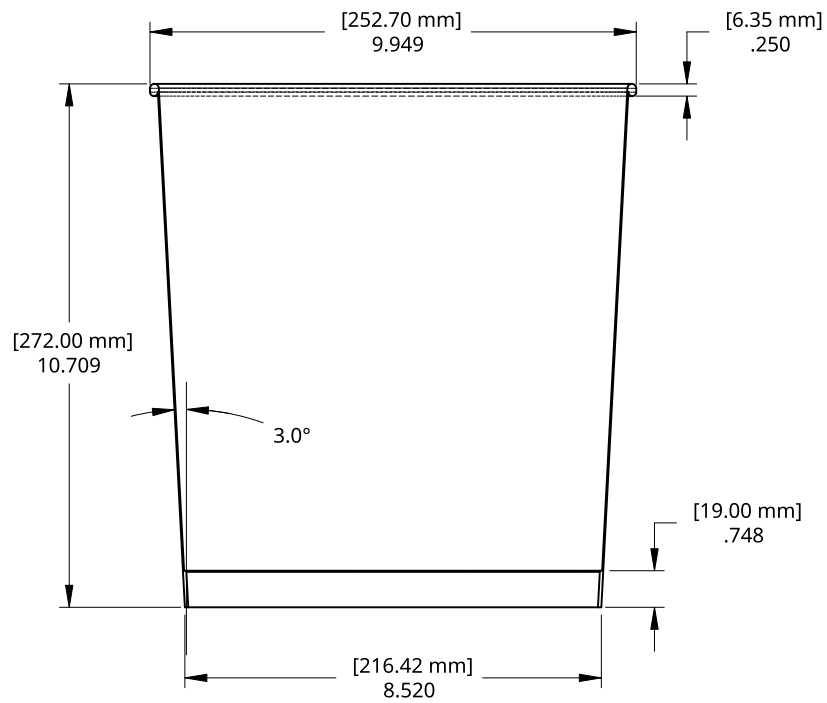

2.75 GALLON CUP (10.41 LITRE) ◀

2.75 GALLON CUP (10.41 LITRE) PROPERTIES:

Maximum Fill Volume: 2.83 Gal / 10.7 L

Practical Volume: 2.75 Gal / 10.4 L

Stack Height: 57.4" / 64 Cups

Disc Material: 18 PT, Polycoated 2 Sides, 1/2 x 1/2 mil

Skirt Material: 28 PT, Polycoated 2 Sides, 1/2 x 1/2 mil

COMP 255MM LID 2.75 GALLON LID PROPERTIES:

Disc Material: 18 PT, Polycoated 2 Sides, 1/2 x 1/2 PT

Plastic Material: HDPE

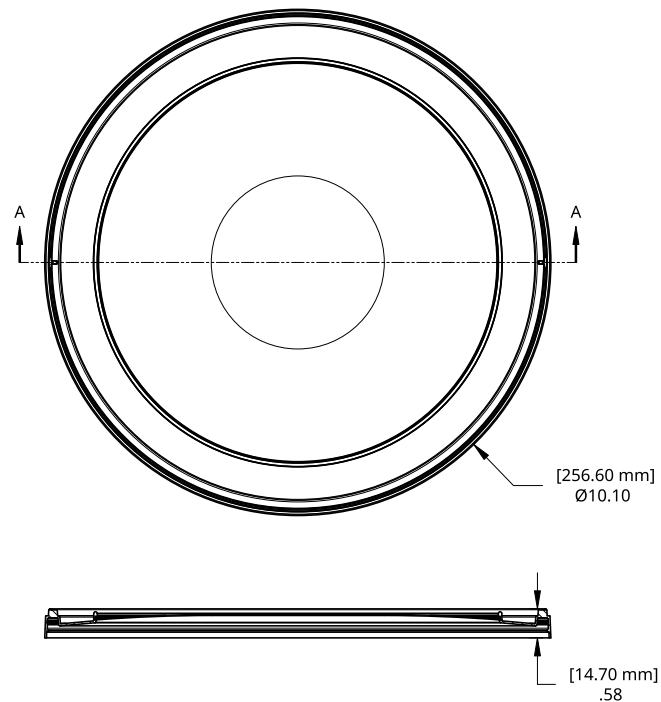

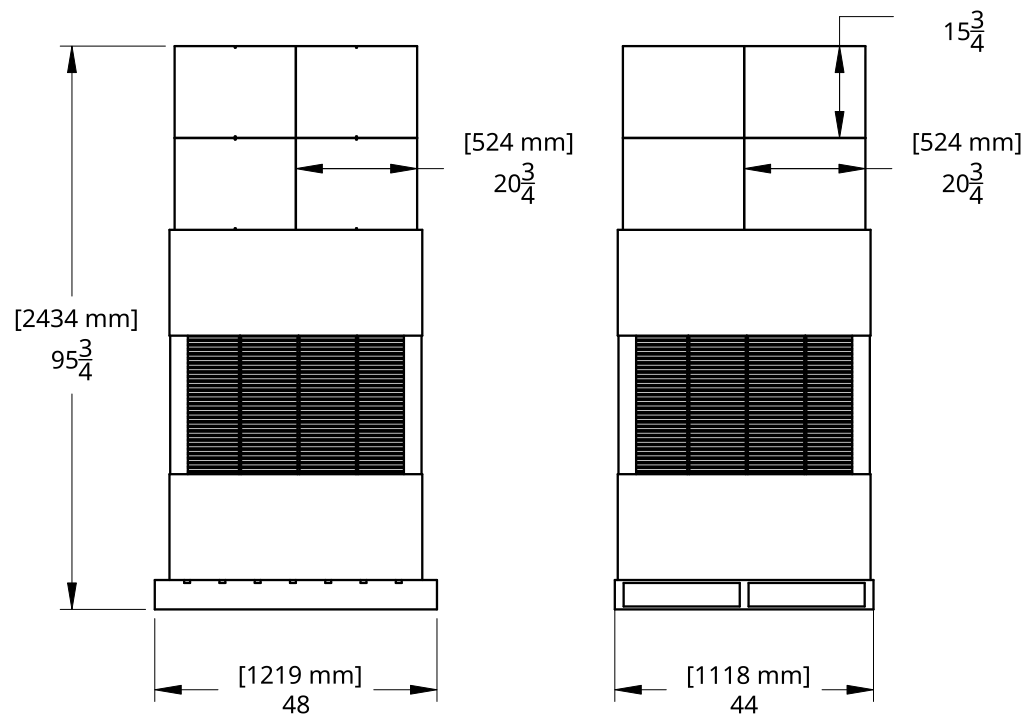
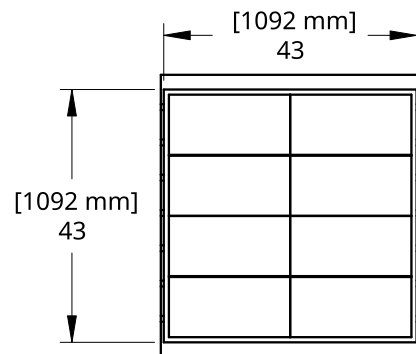

2.75 GALLON CUP (10.41 LITRE) PACKAGING ◀

2.75 GALLON CUP (10.41 LITRE) PACKAGING CONFIGURATIONS:

2.75 Gallon Cup (10.41 Litre):

64 Cups Per Stack - 1,024 Per Pallet
16 Stacks Per Pallet
534 lbs Per Pallet
Pallet Dimensions: 44" x 44" x 95"

COMP 255MM LID 2.75 GALLON LID PACKAGING CONFIGURATIONS:

Comp 216mm Composite Lid:

128 Per Case - 1,024 Per Pallet
4 Cases Per Layer
2 Layers Per Pallet
8 Cases Per Pallet
17 lbs Per Case
534 lbs Per Pallet
Pallet Dimensions: 44" x 44" x 94.75"
Box Size: 21" x 21" x 15"

CUP LID COMBINATIONS ◀



ICE CREAM CUPS	70mm Tab Lid	75.5mm Tab Lid	75mm Paper Lid	82mm Paper Lid	87mm CoverAll Lid	75mm Plug Lid	76.7mm Heat Seal	78mm Heat Seal	83mm Heat Seal	86mm Heat Seal	89mm Heat Seal	97mm Heat Seal	99mm Heat Seal	118mm Heat Seal
3 OZ S ¹	✓		✓				✓	✓						
3 OZ T ¹	✓					✓		✓						
3.5 OZ ¹	✓		✓				✓	✓						
4 OZ ¹		✓		✓					✓	✓				
8 OZ					✓						✓			
8 OZ Squat													✓	
12 OZ Malt					✓						✓			
12 OZ Squat												✓ ²		
12 OZ Short Squat													✓	
14 OZ													✓	
16 OZ													✓	
24 OZ														
500 ML													✓	
32 OZ														✓
1 Litre														✓
48 OZ Tall														
56 OZ Tall														
2 Litre														
64 OZ Tall														
48 OZ Non Round														
56 OZ Non Round														
64 OZ Non Round														
2.75 Gallon														

¹The various lids for this product can be configured in several ways. For example, Tab lid, spoon, heat seal lid. Heat seal lid, cover all lid, tab lid. Tab lid, spoon, cover all lid.

²We do not currently have tooling for this heat seal lid. If you have an interest if a heat seal lid for this size please ask.

ICE CREAM CUPS	Non Round Heat Seal	90 mm Spiral Wound Lid	100 mm Spiral Wound Lid	SecurTec 100 Comp Lid	110 mm Spiral Wound Lid	125 mm Spiral Wound Lid	SecurTec 125 Comp Lid	160 mm Spiral Wound Lid	SecurTec 160 Comp Lid	170 mm Spiral Wound Lid	176mm Non Comp Lid	SecurTec 176 Comp Lid	176mm Paper Lid	2.75 Gallon Lid
3 OZ S ¹														
3 OZ T ¹														
3.5 OZ ¹														
4 OZ ¹														
8 OZ														
8 OZ Squat			✓	✓										
12 OZ Malt														
12 OZ Squat		✓												
12 OZ Short Squat			✓	✓										
14 OZ			✓	✓										
16 OZ			✓	✓										
24 OZ					✓									
500 ML			✓	✓										
32 OZ						✓	✓							
1 Litre						✓	✓							
48 OZ Tall								✓	✓					
56 OZ Tall								✓	✓					
2 Litre								✓	✓					
64 OZ Tall										✓				
48 OZ Non Round	✓										✓	✓	✓	
56 OZ Non Round	✓										✓	✓	✓	
64 OZ Non Round	✓										✓	✓	✓	
2.75 Gallon														✓



A young boy with short brown hair, wearing large black-rimmed glasses, a light-colored bow tie, and a cardigan, is smiling and holding a waffle cone with a scoop of ice cream. The entire image is overlaid with a semi-transparent red filter. The text 'ADDITIONAL LIDS & SEALS ◀' is positioned in the bottom left corner of the image.

**ADDITIONAL
LIDS & SEALS ◀**

TAB LIDS ◀

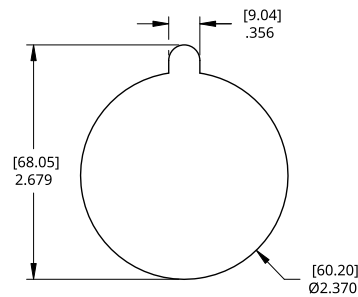

60 MM (2.38") TAB LID

60 MM TAB LID PROPERTIES:

Disc Material: 18 PT, Polycoated
2 Sides, 1/2 x 1/2 mil

PACKAGING CONFIGURATIONS:

60 mm (2.38") Tab Lid:

10,000 Per Case
550,000 Per Pallet
11 Cases Per Layer
5 Layers Per Pallet
55 Cases Per Pallet
26 lbs Per Case
1465 lbs Per Pallet
Pallet Dimensions:
48" X 40" X 61"
Box Size: 14" X 11" X 11"

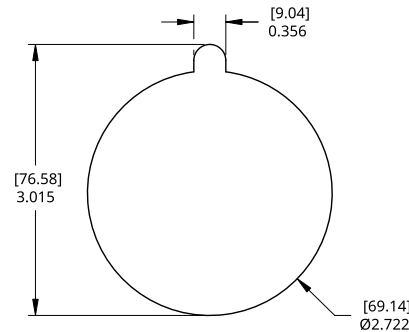

70 MM (2.72") TAB LID

70 MM TAB LID PROPERTIES:

Disc Material: 18 PT, Polycoated
2 Sides, 1/2 x 1/2 mil

PACKAGING CONFIGURATIONS:

70 mm (2.72") Tab Lid:

10,000 Per Case
550,000 Per Pallet
11 Cases Per Layer
5 Layers Per Pallet
55 Cases Per Pallet
32 lbs Per Case
1795 lbs Per Pallet
Pallet Dimensions:
48" X 40" X 56"
Box Size: 12" X 14" X 10"

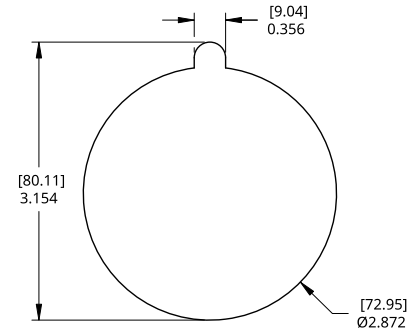

73 MM (2.87") TAB LID

73 MM TAB LID PROPERTIES:

Disc Material: 18 PT, Polycoated
2 Sides, 1/2 x 1/2 mil

PACKAGING CONFIGURATIONS:

73 mm (2.87") Tab Lid:

6,600 Per Case
460,800 Per Pallet
12 Cases Per Layer
4 Layers Per Pallet
48 Cases Per Pallet
34 lbs Per Case
1667 lbs Per Pallet
Pallet Dimensions :
48" X 40" X 52"
Box Size: 13" X 13" X 12"

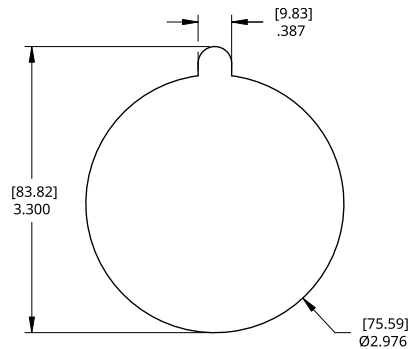

75.5 MM (2.97") TAB LID

75.5 MM TAB LID PROPERTIES:

Disc Material: 18 PT, Polycoated
2 Sides, 1/2 x 1/2 mil

PACKAGING CONFIGURATIONS:

75.5 mm (2.97") Tab Lid:

10,000 Per Case
360,000 Per Pallet
9 Cases Per Layer
4 Layers Per Pallet
36 Cases Per Pallet
39 lbs Per Case
1439 lbs Per Pallet
Pallet Dimensions: 48" x 40" x 48"
Box Size: 13" x 16" x 10"

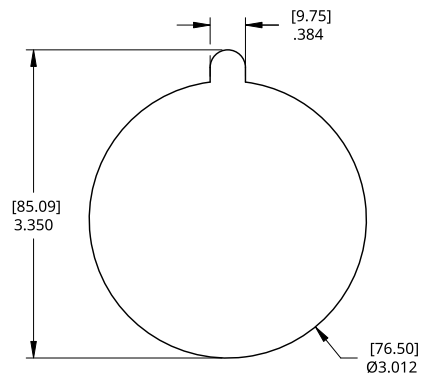

76.5 MM (3.01") TAB LID

76.5 MM TAB LID PROPERTIES:

Disc Material: 18 PT, Polycoated
2 Sides, 1/2 x 1/2 mil

PACKAGING CONFIGURATIONS:

76.5 mm (3.01") Tab Lid:

10,000 Per Case
360,000 Per Pallet
9 Cases Per Layer
4 Layers Per Pallet
36 Cases Per Pallet
39 lbs Per Case
1439 lbs Per Pallet
Pallet Dimensions: 48" x 40" x 48"
Box Size: 13" x 16" x 10"

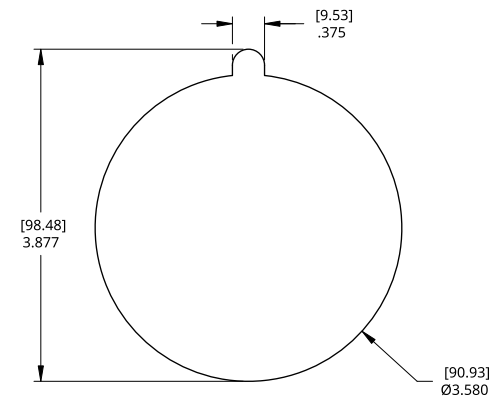

89 MM (3.58") TAB LID

89 MM TAB LID PROPERTIES:

Disc Material: 18 PT, Polycoated
2 Sides, 1/2 x 1/2 mil

PACKAGING CONFIGURATIONS:

89 mm (3.58") Tab Lid:

6,000 Per Case
162,000 Per Pallet
9 Cases Per Layer
3 Layers Per Pallet
27 Cases Per Pallet
32 lbs Per Case
899 lbs Per Pallet
Pallet Dimensions: 48" x 40" x 36"
Box Size: 12" x 15" x 10"

DISC LIDS ◀

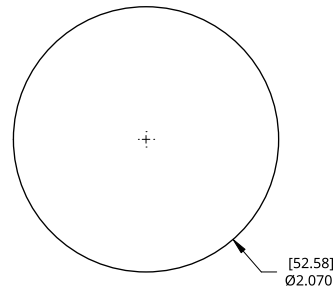
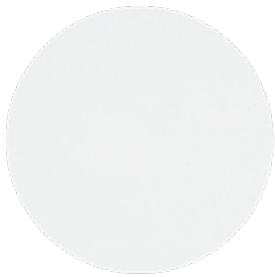

52.5 MM (2.07") DISC LID

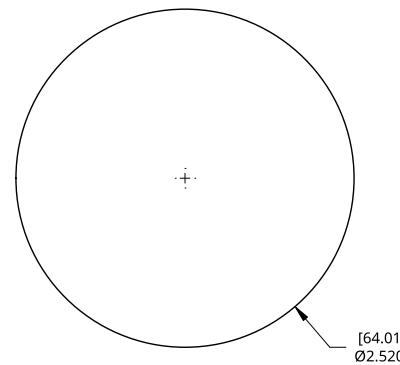

64 MM (2.52") DISC LID

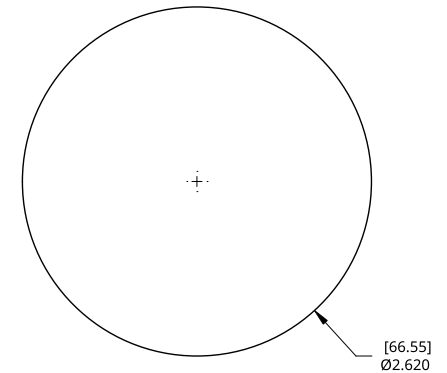

66.5 MM (2.62") DISC LID

52.5 MM DISC LID PROPERTIES:

Disc Material: 18 PT, Polycoated
2 Sides, 1/2 x 1/2 mil

PACKAGING CONFIGURATIONS:

52.5 mm (2.07") Disc Lid

10,000 Per Case
480,000 Per Pallet
16 Cases Per Layer
3 Layers Per Pallet
48 Cases Per Pallet
26 lbs Per Case
1283 lbs Per Pallet
Pallet Dimensions:
48" x 40" x 36"
Box Size: 15" x 12" x 10"

64 MM DISC LID PROPERTIES:

Disc Material: 18 PT, Polycoated
2 Sides, 1/2 x 1/2 mil

PACKAGING CONFIGURATIONS:

64 mm (2.52") Disc Lid

10,000 Per Case
330,000 Per Pallet
11 Cases Per Layer
3 Layers Per Pallet
33 Cases Per Pallet
28 lbs Per Case
959 lbs Per Pallet
Pallet Dimensions:
48" x 40" x 38"
Box Size: 14" x 11" x 11"

66.5 MM DISC LID PROPERTIES:

Disc Material: 18 PT, Polycoated
2 Sides, 1/2 x 1/2 mil

PACKAGING CONFIGURATIONS:

66.5 mm (2.62") Disc Lid:

10,000 Per Case
330,000 Per Pallet
11 Cases Per Layer
3 Layers Per Pallet
33 Cases Per Pallet
31 lbs Per Case
1058 lbs Per Pallet
Pallet Dimensions:
48" x 40" x 38"
Box Size: 14" x 12" x 11"

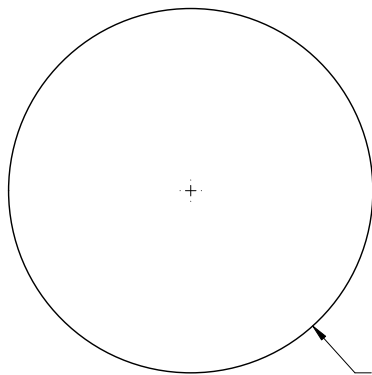

[68.00]
Ø2.677

68 MM (2.677") DISC LID

68 MM DISC LID PROPERTIES:

Disc Material: 18 PT, Polycoated
2 Sides, 1/2 x 1/2 mil

PACKAGING CONFIGURATIONS:

68 mm (2.677") Disc Lid:

10,000 Per Case
330,000 Per Pallet
11 Cases Per Layer
3 Layers Per Pallet
33 Cases Per Pallet
32 lbs Per Case
1091 lbs Per Pallet
Pallet Dimensions: 48" x 40" x 38"
Box Size: 14" x 12" x 11"

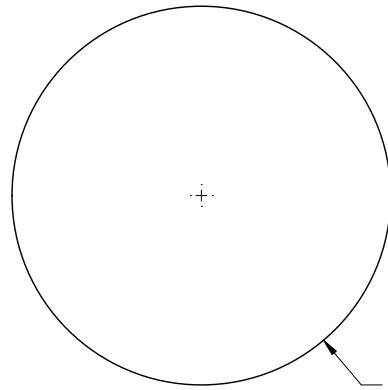

[69.60]
Ø2.740

69.5 MM (2.74") DISC LID

69.5 MM DISC LID PROPERTIES:

Disc Material: 18 PT, Polycoated
2 Sides, 1/2 x 1/2 mil

PACKAGING CONFIGURATIONS:

69.5 mm (2.74") Disc Lid:

10,000 Per Case
330,000 Per Pallet
11 Cases Per Layer
3 Layers Per Pallet
33 Cases Per Pallet
32 lbs Per Case
1091 lbs Per Pallet
Pallet Dimensions: 48" x 40" x 38"
Box Size: 14" x 12" x 11"

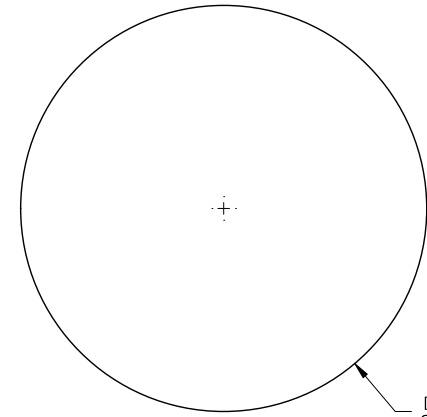

[76.20]
Ø3.000

76.5 MM (3.0") DISC LID

76.5 MM DISC LID PROPERTIES:

Disc Material: 18 PT, Polycoated
2 Sides, 1/2 x 1/2 mil

PACKAGING CONFIGURATIONS:

76.5 mm (3.0") Disc Lid:

10,000 Per Case
360,000 Per Pallet
9 Cases Per Layer
4 Layers Per Pallet
36 Cases Per Pallet
38 lbs Per Case
1403 lbs Per Pallet
Pallet Dimensions: 48" x 40" x 48"
Box Size: 13" x 16" x 10"

TEAR DROP HEAT SEAL LIDS ◀



PPP STRUCTURE:
PET/PE/Paper/PE/PET/Sealing Layer

*Layers of polyester
provide tear resistance

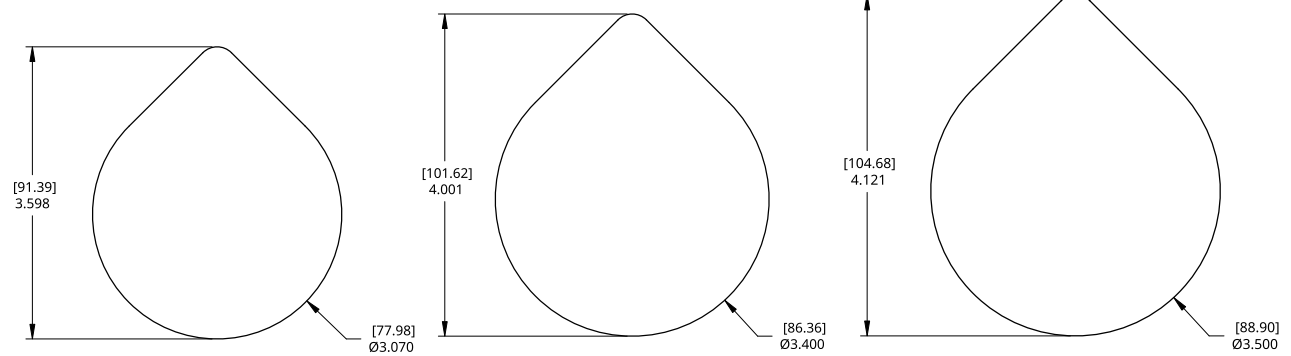

78 MM (3.08") HEAT SEAL

86 MM (3.4") HEAT SEAL

89 MM (3.5") HEAT SEAL

78 MM HEAT SEAL PROPERTIES:

Paper Material: PPP

PACKAGING CONFIGURATIONS:

78 mm (3.08") Teardrop Heat Seal Lid

18,000 Per Case –
864,000 Per Pallet
12 Cases Per Layer
4 Layers Per Pallet
48 Cases Per Pallet
25 lbs Per Case
1275 lbs Per Pallet
Pallet Dimensions:
48" x 40" x 42.5"
Box Size: 9.75 x 13.0 x 9.125"

86 MM HEAT SEAL PROPERTIES:

Paper Material: PPP

PACKAGING CONFIGURATIONS:

86 mm (3.4") Teardrop Heat Seal Lid

9,000 Per Case –
576,000 Per Pallet
16 Cases Per Layer
4 Layers Per Pallet
64 Cases Per Pallet
15 lbs Per Case
995 lbs Per Pallet
Pallet Dimensions:
48" x 40" x 53"
Box Size: 11" x 9" x 12"

89 MM HEAT SEAL PROPERTIES:

Paper Material: PPP

PACKAGING CONFIGURATIONS:

89 mm (3.5") Teardrop Heat Seal Lid

9,000 Per Case –
576,000 Per Pallet
16 Cases Per Layer
4 Layers Per Pallet
64 Cases Per Pallet
17 lbs Per Case
1123 lbs Per Pallet
Pallet Dimensions:
48" x 40" x 53"
Box Size: 11" x 9" x 12"

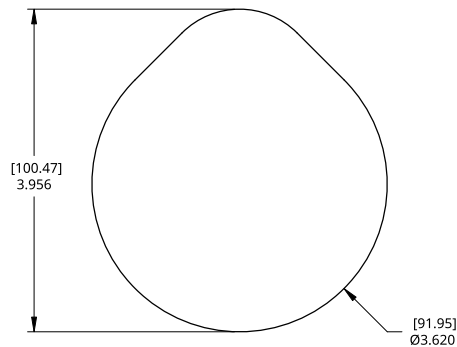

92 MM (3.62") HEAT SEAL

92 MM HEAT SEAL PROPERTIES:

Paper Material: PPP

PACKAGING CONFIGURATIONS:

92 mm (3.62")

Teardrop Heat Seal Lid

8,100 Per Case
 518,000 Per Pallet
 16 Cases Per Layer
 4 Layers Per Pallet
 64 Cases Per Pallet
 23 lbs Per Case
 1472 lbs Per Pallet
 Pallet Dimensions:
 48" x 40" x 41"
 Box Size: 12" x 8" x 9"

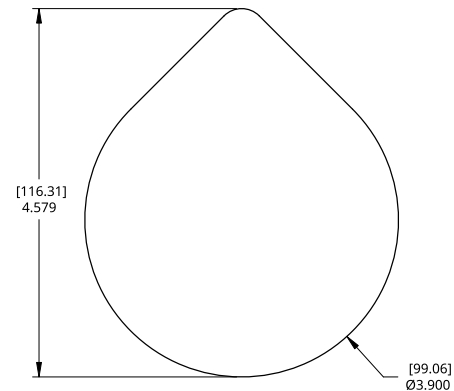

99 MM (3.9") HEAT SEAL

99 MM HEAT SEAL PROPERTIES:

Paper Material: PPP

PACKAGING CONFIGURATIONS:

99 mm (3.9")

Teardrop Heat Seal Lid

8,100 Per Case
 518,000 Per Pallet
 16 Cases Per Layer
 4 Layers Per Pallet
 64 Cases Per Pallet
 23 lbs Per Case
 1472 lbs Per Pallet
 Pallet Dimensions:
 48" x 40" x 41"
 Box Size: 12" x 8" x 9"

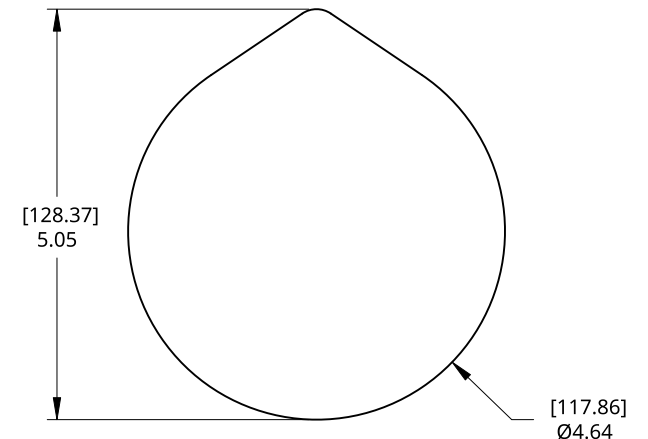

118 MM (4.64") HEAT SEAL

118 MM HEAT SEAL PROPERTIES:

Paper Material: PPP

PACKAGING CONFIGURATIONS:

118 mm (4.64")

Teardrop Heat Seal Lid

8,100 Per Case
 324,000 Per Pallet
 10 Cases Per Layer
 4 Layers Per Pallet
 40 Cases Per Pallet
 30 lbs Per Case
 1235 lbs Per Pallet
 Pallet Dimensions:
 48" x 40" x 41"
 Box Size: 15" x 10" x 9"

HEAT SEAL LIDS ◀

PPP STRUCTURE:
PET/PE/Paper/PE/PET/Sealing Layer

*Layers of polyester
provide tear resistance

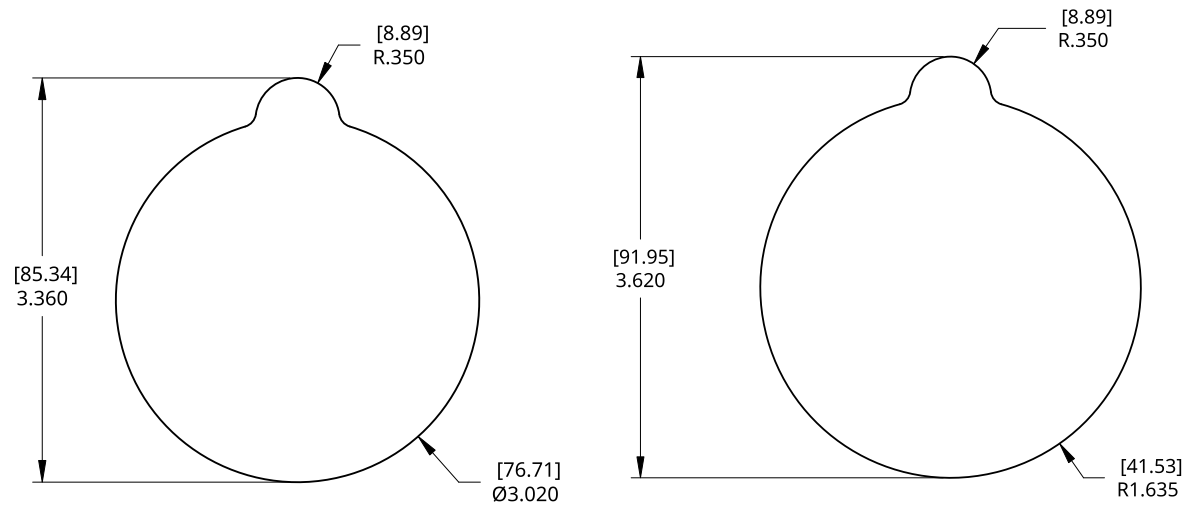

76.7 MM (3.02") HEAT SEAL

83 MM (3.27") HEAT SEAL

76.7 MM HEAT SEAL PROPERTIES:

Paper Material: PPP

PACKAGING CONFIGURATIONS:

76.7 mm (3.02") Heat Seal Lid

16,200 Per Case
777,600 Per Pallet
12 Cases Per Layer
4 Layers Per Pallet
48 Cases Per Pallet
Pallet Dimensions: 48" x 40" x 45"
Box Size: 14" x 10" x 10"

83 MM HEAT SEAL PROPERTIES:

Paper Material: PPP

PACKAGING CONFIGURATIONS:

83 mm (3.22") Heat Seal Lid

8,100 Per Case
518,400 Per Pallet
16 Cases Per Layer
4 Layers Per Pallet
64 Cases Per Pallet
13.5 lbs Per Case
899 lbs Per Pallet
Pallet Dimensions: 48" x 40" x 45"
Box Size: 12" x 8" x 9"

DIE CUT HEAT SEAL LIDS ◀

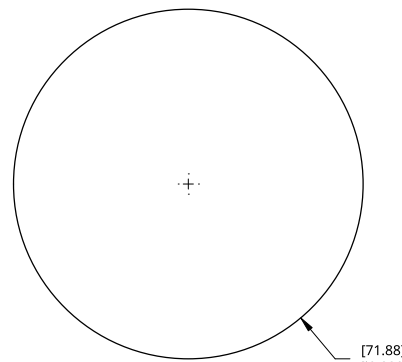

[71.88]
Ø2.830

72 MM (2.835") HEAT SEAL

72 MM HEAT SEAL PROPERTIES:

Paper Material: 64# with Hot Melt Adhesive

PACKAGING CONFIGURATIONS:

72 mm (2.835") Round Die Cut Heat Seal Lid
 35,000 Per Case
 1,260,000 Per Pallet
 9 Cases Per Layer
 4 Layers Per Pallet
 36 Cases Per Pallet
 42 lbs Per Case
 1547 lbs Per Pallet
 Pallet Dimensions:
 48" x 40" x 46"
 Box Size: 16" x 13" x 10"

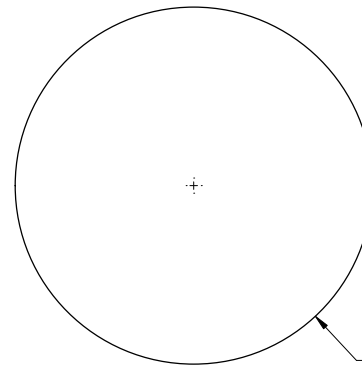

[73.41]
Ø2.89

73 MM (2.87") HEAT SEAL

73 MM HEAT SEAL PROPERTIES:

Paper Material: 55# with Hot Melt Adhesive

PACKAGING CONFIGURATIONS:

73 mm (2.87") Round Die Cut Heat Seal Lid
 39,000 Per Case
 1,404,000 Per Pallet
 9 Cases Per Layer
 4 Layers Per Pallet
 36 Cases Per Pallet
 44 lbs Per Case
 1619 lbs Per Pallet
 Pallet Dimensions:
 48" x 40" x 46"
 Box Size: 16" x 13" x 10"

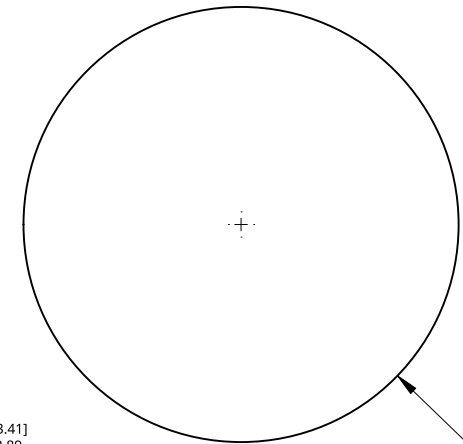

[90.93]
Ø3.58

91MM (3.58") HEAT SEAL

91 MM DISC LID PROPERTIES:

Disc Material: 55# with Hot Melt Adhesive

PACKAGING CONFIGURATIONS

91 mm (3.58") Disc Lid:
 10,500 Per Case -
 672,000 Per Pallet
 16 Cases Per Layer
 4 Layers Per Pallet
 64 Cases Per Pallet
 22 lbs Per Case
 1443 lbs Per Pallet
 Pallet Dimensions:
 48" x 40" x 41"
 Box Size: 12" x 8" x 9"

NON ROUND HEAT SEAL LIDS ◀

PPP STRUCTURE:
PET/PE/Paper/PE/PET/Sealing Layer

*Layers of polyester
provide tear resistance

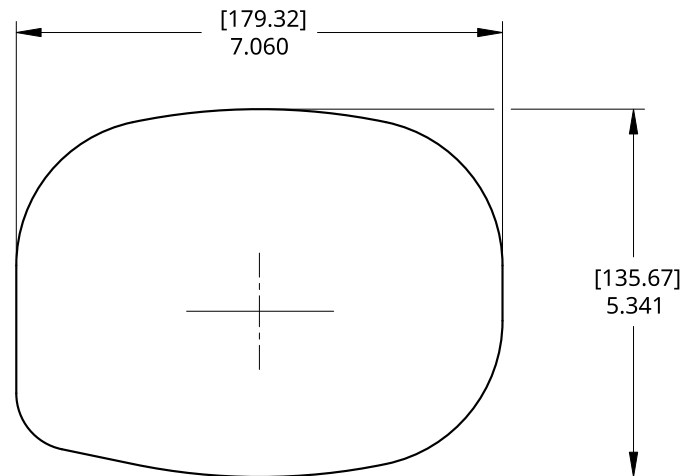

NON ROUND HEAT SEAL

NON ROUND HEAT SEAL PROPERTIES:

Paper Material: PPP

PACKAGING CONFIGURATIONS:

Non Round Heat Seal Lid

3,200 Per Case

144,000 Per Pallet

9 Cases Per Layer

5 Layers Per Pallet

45 Cases Per Pallet

Pallet Dimensions: 48" x 40" x 35"

Box Size: 12" x 15" x 6"





DAIRY PACKAGING ◀



8 OZ HALF PINT GLASS REFILLABLE BOTTLES ◀

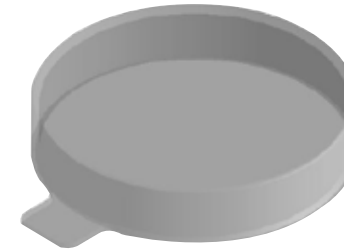

8 OZ (236 ML) / 56 MM NECK



8 OZ PALLET PROPERTIES:

8 oz Bottles - Carton Packed:

Bottle Weight: 0.54 lbs
 Pallet Weight: 980 lbs
 Pallet Dimensions: 40"W x 48"L x 42"H
 Full Truck Quantity: 38,880
 *24 Pallet Max
 Bottles/Carton: 60
 Carton/Pallet: 27
 Bottles/Pallet: 1,620
 Box Size: 12" x 14" x 12"

Bottles are packed neck up,
 cartons have chipboard dividers

8 oz Bottles - Bulk Packed:

Bottle Weight: 0.54 lbs
 Pallet Weight: 1,138 lbs
 Pallet Dimensions: 40"W x 48"L x 84"H
 Full Load Quantity: 45,360
 *24 Pallet Max
 Bottles/Layer: 270
 Bottles/Pallet: 1,890

56 MM FRIGI SEAL PLASTIC CAPS

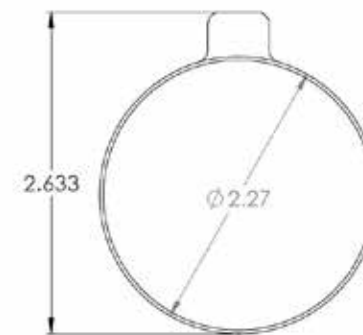

56 MM FRIGI SEAL PLASTIC CAPS:

1000/CASE
 27 Cases Per Pallet
 27,000 lids Per Pallet
 14 lbs Per Box
 413 lbs Per Skid
 Pallet Dimensions: 40"W x 48"L x 44"H
 Box Size: 17" x 16" x 13"



12 OZ (355 ML) / 48 MM NECK

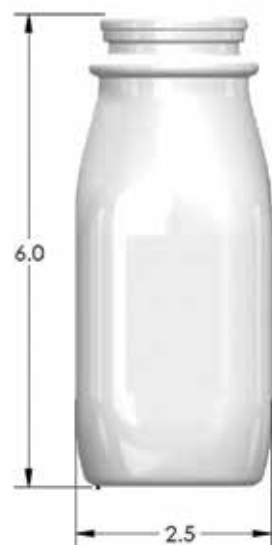

12 OZ GLASS REFILLABLE BOTTLES ◀

12 OZ PALLET PROPERTIES:

12 oz Bottles - Carton Packed:

Bottle Weight: 0.63lbs
Pallet Weight: 1,665 lbs
Pallet Dimensions: 40"W x 48"L x 69"H
Full truck Quantity: 62,400
Bottles/Carton: 24
Cartons/Pallet: 100
Bottles/Pallet: 2,400
Box Size: 16" x 11" x 7"

Bottles are packed neck up, in open top cartons with chipboard dividers

12 oz Bottles - Bulk Packed:

Bottle Weight: 0.63 lbs
Pallet Weight: 2,228 lbs
Pallet Dimensions: 44"W x 56"L x 67.785"H
Full Load Quantity: 67,200 btls
Bottles/ Layer: 336 btls
Bottles/Pallet: 3,360
*Max 20 Pallets/Truck



12 OZ THREADED GLASS REFILLABLE BOTTLES ◀

12 OZ PALLET PROPERTIES:

12 oz Bottles - Bulk Packed:

Bottle Weight: 0.63 lbs

Pallet Weight: 2,228 lbs

Pallet Dimensions: 44"W x 56"L x 67.785"H

Full Load Quantity: 67,200 btls

Bottles/Layer: 336 btls

Bottles/Pallet: 3,360

*Max 20 Pallets/truck

12 OZ (355 ML) / 48 MM NECK





16 OZ (473 ML) / 48 MM NECK



16 OZ SQUAT PINT GLASS REFILLABLE BOTTLES ◀

16 OZ PALLET PROPERTIES:

16 oz Bottles - Carton Packed:

Bottle Weight: 0.72 lbs

Pallet Weight: 1,938 lbs

Pallet Dimensions: 40"W x 48"L x 96"H

Full Load Quantity: 51,744

*22 Pallet Max due to weight restrictions

Bottles/Carton: 24

Carton/Pallet: 98

Bottles/Pallet: 2,352

Box Size: 14" x 21" x 6"

Bottles are packed neck up, in open top cartons with chipboard dividers

16 oz Bottles - Bulk Packed:

Bottle Weight: 0.72 lbs

Pallet Weight: 1,680 lbs

Pallet Dimensions: 54"W x 44"L x 80"H

Full Load Quantity: 54,080 btl

Bottles/Layer: 208 btl

Bottles/Pallet: 2,704

*Max 20 Pallets/truck



16 OZ (473 ML) / 48 MM NECK

16 OZ THREADED SQUAT PINT GLASS REFILLABLE BOTTLES ◀

16 OZ PALLET PROPERTIES:

16 oz Bottles - Bulk Packed:

Bottle Weight: 0.72 lbs

Pallet Weight: 1,680 lbs

Pallet Dimensions: 54"W x 44"L x 80"H

Full Load Quantity: 54,080 btls

Bottles/Layer: 208 btls

Bottles/Pallet: 2,704

*Max 20 Pallets/truck





16 OZ (473 ML) / 48 MM NECK



16 OZ TALL PINT GLASS REFILLABLE BOTTLES ◀

16 OZ PALLET PROPERTIES:

16 oz Bottles - Carton Packed:

Bottle Weight: .83 lbs

Pallet Weight: 2,184 lbs

Pallet Dimensions: 40"W x 50"L x 85"H

Full Load Quantity: 48,000

*20 Pallet Max due to weight restrictions

Bottles/Carton: 24

Carton/Pallet: 100

Bottles/Pallet: 2,400

Box Size: 17" x 12" x 8"

Bottles are packed neck down, in open top cartons with chipboard dividers

16 oz Bottles - Bulk Packed:

Bottle Weight: 0.83 lbs

Pallet Weight: 2,248 lbs

Pallet Dimensions: 44"W x 56"L x 66"H

Full Load Quantity: 48,640 btl's

Bottles/Layer: 320 btl's

Bottles/Pallet: 2,560

*Max 19 Pallets/truck



16 OZ THREADED TALL PINT GLASS REFILLABLE BOTTLES ◀

16 OZ PALLET PROPERTIES:

16 oz Bottles - Bulk Packed:

Bottle Weight: 0.83 lbs

Pallet Weight: 2,248 lbs

Pallet Dimensions: 44"W x 56"L x 66"H

Full Load Quantity: 48,640 btl

Bottles/Layer: 320 btl

Bottles/Pallet: 2,560

*Max 19 Pallets/truck

16 OZ (473 ML) / 48 MM NECK



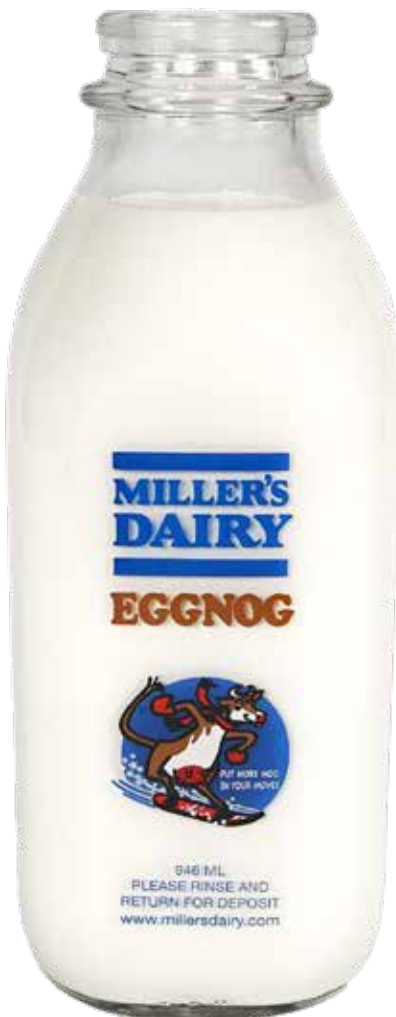

32 OZ (946 ML) / 48 MM NECK

32 OZ SQUARE QUART GLASS REFILLABLE BOTTLES ◀

32 OZ PALLET PROPERTIES:

32 oz Bottles - Carton Packed:

Bottle Weight: 1.15 lbs
 Pallet Weight: 1,715 lbs
 Pallet Dimensions: 40"W x 48"L x 81"H
 Full Load Quantity: 32,256
 *22 Pallet Max
 Bottles/Carton: 24
 Carton/Pallet: 56
 Bottles/Pallet: 1,344
 Box Size: 21" x 14" x 9"

Bottles are packed neck up, in open top cartons with chipboard dividers

32 oz Bottles - Bulk Packed:

Bottle Weight: 1.15 lbs
 Pallet Weight: 2,121 lbs
 Pallet Dimensions: 41"W x 54.75"L x 85.3" H
 Full Load Quantity: 35,160 btl
 Bottles/Layer: 192 btl
 Bottles/Pallet: 1,728
 *Max 20 Pallets/truck



32 OZ (946 ML) / 48 MM NECK

32 OZ ROUND QUART GLASS REFILLABLE BOTTLES ◀

32 OZ PALLET PROPERTIES:

32 oz Bottles - Carton Packed:

Bottle Weight: 1.18 lbs

Pallet Weight: 1,565 lbs

Pallet Dimensions: 40"W x 48"L x 97.1"H

Full Load Quantity: 25,920

*20 Pallet Max

Bottles/Carton: 12

Carton/Pallet: 90

Bottles/Pallet: 1,080

Box Size: 12" x 16" x 10"

Bottles are packed neck down, bottom of carton untaped with chipboard dividers

32 oz Bottles - Bulk Packed:

Bottle Weight: 1.18lbs

Pallet Weight: 1,850 lbs

Pallet Dimensions: 44"W x 56"L x 84"H

Full Load Quantity: 32,032

Bottles/Layer: 182

Bottles/Pallet: 1,450

*Bulk Pallets only, can be returned to the manufacture plant for refund.

Return Freight is customer's responsibility



1 LITRE (34OZ) / 48 MM NECK

1 LITRE, 34 OZ GLASS REFILLABLE BOTTLES ◀

34 OZ PALLET PROPERTIES:

34 oz Bottles - Carton Packed:

Bottle Weight: 1.41 lbs
 Pallet Weight: 1,984 lbs
 Pallet Dimensions: 40"W x 48"L x 80"H
 Full Load Quantity: 28,224
 *21 Pallet Max due to pallet size
 Bottles/Carton: 12
 Carton/Pallet: 112
 Bottles/Pallet: 1,344
 Box Size: 10" x 10" x 14"

Bottles are packed neck down, in open top cartons with chipboard dividers

34 oz Bottles - Bulk Packed:

Bottle Weight: 1.41 lbs
 Pallet Weight: 2,179 lbs
 Pallet Dimensions: 44"W x 56"L x 72"H
 Full Load Quantity: 29,120 btl
 Bottles/Layer: 208 btl
 Bottles/Pallet: 1,456
 *Max 20 Pallets/truck



64 OZ (1.89L) / 38 MM NECK

64 OZ HALF GALLON GLASS REFILLABLE BOTTLES ◀

64 OZ PALLET PROPERTIES:

64 oz Bottles - Carton Packed:

Bottle Weight: 2 lbs
 Pallet Weight: 1,707 lbs
 Pallet Dimensions: 43"W x 48"L x 88"H
 Full Load Quantity: 19,008
 *24 Pallet Max
 Bottles/Carton: 9
 Carton/Pallet: 88
 Bottles/Pallet: 792
 Box Size: 12" x 16" x 10"

64 oz Bottles - Bulk Packed:

Bottle Weight: 2 lbs
 Pallet Weight: 2,147 lbs
 Pallet Dimensions: 44"W x 56"L x 86"H
 Full Load Quantity: 19,360 btl
 Bottles/Layer: 121 btl
 Bottles/Pallet: 968
 *Max 20 Pallets/truck

*Repack fee does apply for plain bottles to be packed in cartons

*Natural plastic handles available installed or uninstalled

Bottles are packed neck up, in open top cartons with chipboard dividers



64 OZ (1.89L) / 48 MM NECK

64 OZ HALF GALLON GLASS REFILLABLE BOTTLES ◀

64 OZ PALLET PROPERTIES:

64 oz Bottles - Carton Packed:

Bottle Weight: 2 lbs
 Pallet Weight: 1,707 lbs
 Pallet Dimensions: 43"W x 48"L x 88"H
 Full Load Quantity: 19,008
 *24 Pallet Max
 Bottles/Carton: 9
 Carton/Pallet: 88
 Bottles/Pallet: 792
 Box Size: 12" x 16" x 10"

*Natural plastic handles available installed or uninstalled

Bottles are packed neck down, in open top cartons with chipboard dividers

64 oz Bottles - Bulk Packed:

Bottle Weight: 2 lbs
 Pallet Weight: 2,147 lbs
 Pallet Dimensions: 44"W x 56"L x 86"H
 Full Load Quantity: 19,360 btl
 Bottles/Layer: 121 btl
 Bottles/Pallet: 968
 *Max 20 Pallets/truck

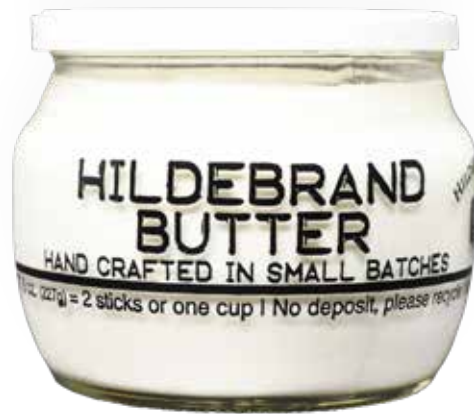

8 OZ (236 ML)



300 L PLASTIC LIDS

8 OZ GLASS JAR ◀

8 OZ PALLET PROPERTIES:

8 oz Jars - Carton Packed:

Jar Weight: 0.34 lbs
 Pallet Weight: 880 lbs
 Pallet Dimensions: 44"W x 48"L x 51"H
 Jars/Carton: 12
 Carton/Pallet: 169
 Jars/Pallet: 2,028
 Box Size: 14" x 11" x 3"

Jars are packed neck up,
 cartons have chipboard dividers

300 L PLASTIC LIDS:

1,500 Lids Per Case
 30 Cases Per Pallet
 45,000 Lids Per Pallet
 19 lbs Per Case
 600 lbs Per Pallet
 Pallet Dimensions: 40"W x 48"L x 80"H
 Case Size: 15" x 15" x 15"



4.70 OZ (139 ML)



4.70 OZ GLASS JAR ◀

4.70 OZ PALLET PROPERTIES:

4.70 oz Jars - Carton Packed:

Jar Weight: 0.172 lbs
 Pallet Weight: 686 lbs
 Pallet Dimensions: 40"W x 48"L x 42"H
 Jars/Carton: 48
 Carton/Pallet: 75
 Jars/Pallet: 3,600
 Box Size: 9" x 7" x 12"

4.70 oz Jars - Bulk Packed:

Jar Weight: 0.172 lbs
 Pallet Weight: 925 lbs
 Pallet Dimensions: 40"W x 48"L x 47"H
 Full Load Quantity: 228,536

*44 Pallet Max, double stacked

Jars/Layer: 371
 Jars/Pallet: 5,194

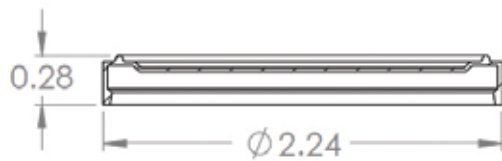

203 CE PLASTIC LIDS

4.70 OZ GLASS JAR ◀

203 CE PLASTIC LIDS:

Lids/Case: 2,750 Sleeved
 Cases/Pallet: 30
 Lids/Pallet: 82,500
 Weight/Box: 19 lbs
 Pallet Weight: 620 lbs
 Pallet Dimensions: 40"W x 48"L x 70"H
 Box Size: 23" x 14" x 13"



FOIL HEAT SEAL LIDS

FOIL HEAT SEAL LIDS:

Lids/Case: 9,000
 Cases/Pallet: 57
 Lids/Pallet: 513,000
 Weight/Box: 13 lbs
 Pallet Weight: 776 lbs
 Pallet Dimensions: 40"W x 48"L x 32"H
 Box Size: 10" x 7" x 9"

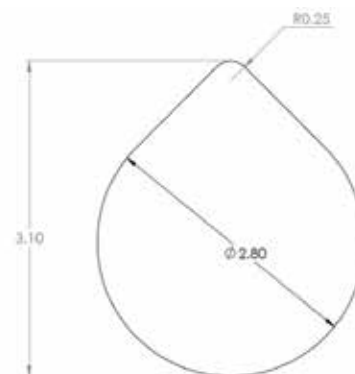

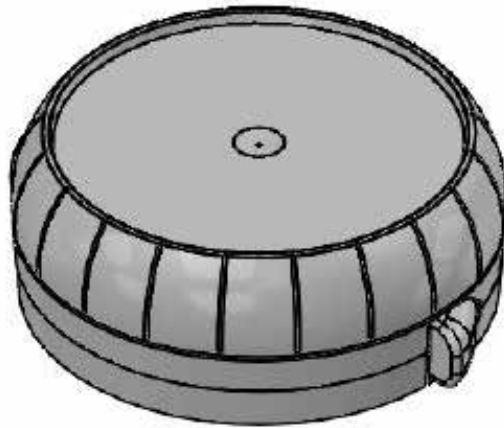

38 MM NECK FINISH

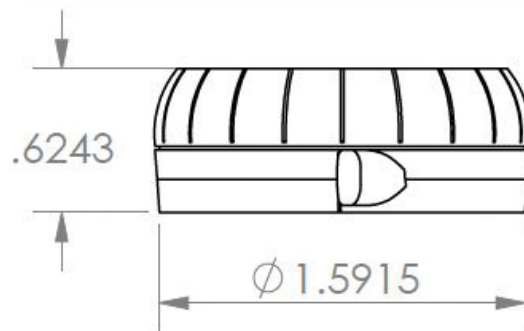

38 MM HANDLE

38 MM TAMPER EVIDENT CAPS ◀

CAP COLORS:

Clear	Pearl Blue	Red
White	Light Blue	Red (non metallic)
Brown	Yellow	Pink
Cream	Orange	Purple
Green		



PALLET PROPERTIES:

Caps Per Carton: 3,500
 Carton Weight: 28.5 lbs
 Carton/Pallet: 12
 Caps/Pallet: 42,000
 Pallet Weight: 392 lbs
 Pallet Dimensions: 40"W x 48"L x 52"H
 Box Size: 24" x 20" x 16"
 Pallets can be double stacked

HANDLE PROPERTIES:

Handles Per Carton: 800
 Carton Weight: 121 lbs
 Carton/Pallet: 56
 Pallet Weight: 707 lbs
 Pallet Dimensions: 40"W x 48"L x 75"H
 Box Size: 21" x 12" x 10"

48 MM TAMPER EVIDENT CAPS ◀

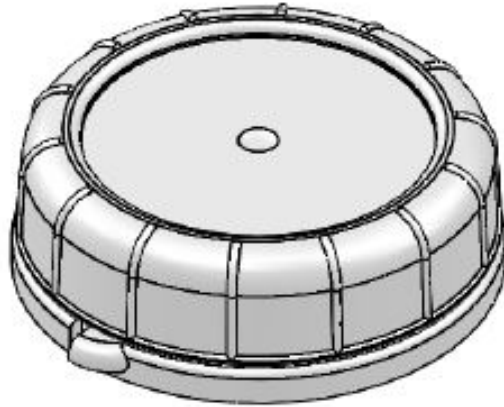

48 MM NECK FINISH

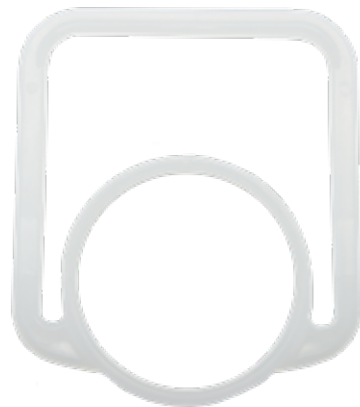
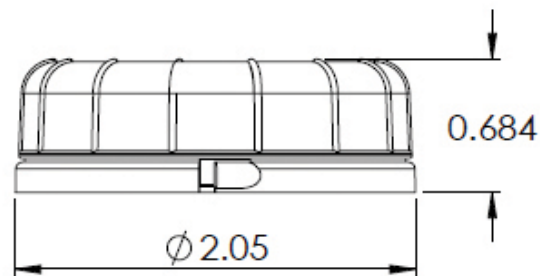

48 MM HANDLE

CAP COLORS:

Clear	Copper	Pink
White	Butterscotch	Purple
Silver	Cream	Dark Blue
Black	Yellow	Pearl Blue
Dark Brown	Orange	Light Blue
Gold	Red	Green

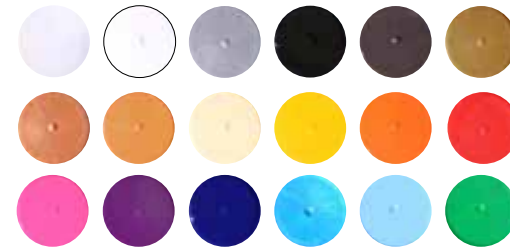

PALLET PROPERTIES:

Caps Per Carton: 2,000
 Carton Weight: 26 lbs
 Carton/Pallet: 12
 Caps/Pallet: 24,000
 Pallet Weight: 347 lbs
 Pallet Dimensions: 40"W x 48"L x 52"H
 Box Size: 24" x 20" x 16"
 Pallets can be double staked

HANDLE PROPERTIES:

Handles Per Carton: 600
 Carton Weight: 121 lbs
 Carton/Pallet: 56
 Pallet Weight: 707 lbs
 Pallet Dimensions: 40"W x 48"L x 75"H
 Box Size: 21" x 12" x 10"



48 MM NECK FINISH



48 MM THREADED TAMPER EVIDENT CAPS ◀

CAP COLORS:

Clear	Copper	Pink
White	Butterscotch	Purple
Silver	Cream	Dark Blue
Black	Yellow	Pearl Blue
Dark Brown	Orange	Light Blue
Gold	Red	Green

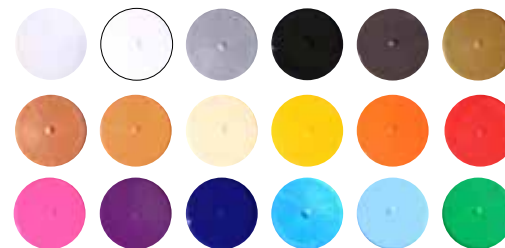

PALLET PROPERTIES:

Caps Per Carton: 2,000
 Carton Weight: 26 lbs
 Carton/Pallet: 12
 Caps/Pallet: 24,000
 Pallet Weight: 347 lbs
 Pallet Dimensions: 40"W x 48"L x 52"H
 Box Size: 24" x 20" x 16"
 Pallets can be double stacked

SQUARE QUART CARRIER ◀

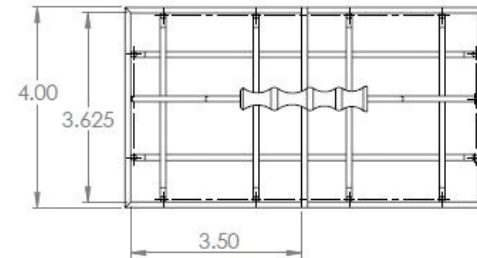
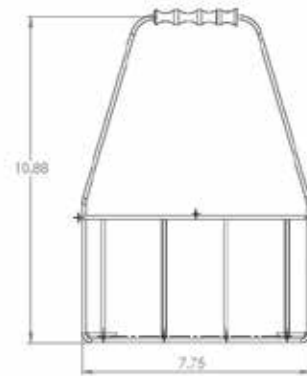
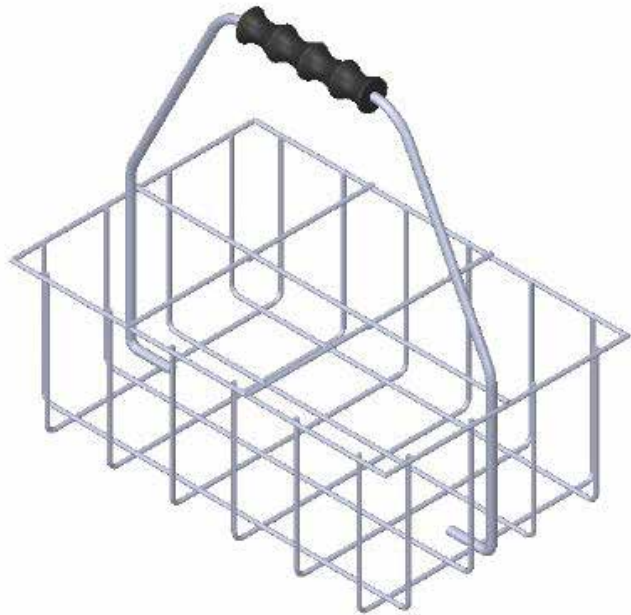

2 CELL QUART CARRIER

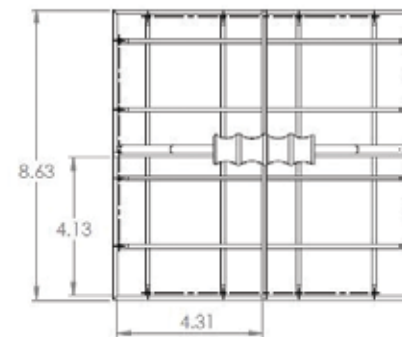
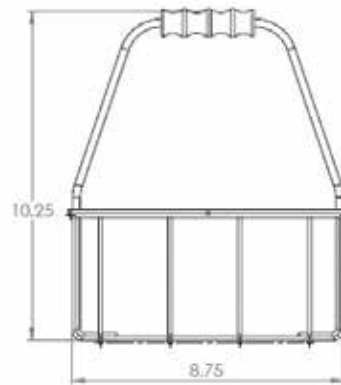

4 CELL QUART CARRIER

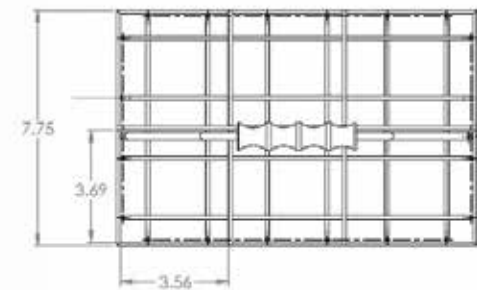
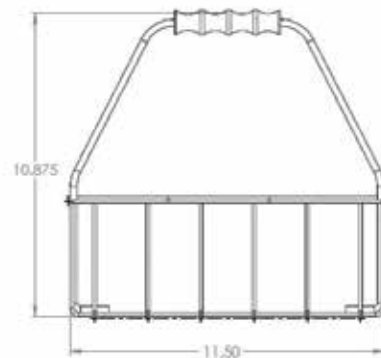

6 CELL QUART CARRIER

HALF GALLON CARRIER ◀

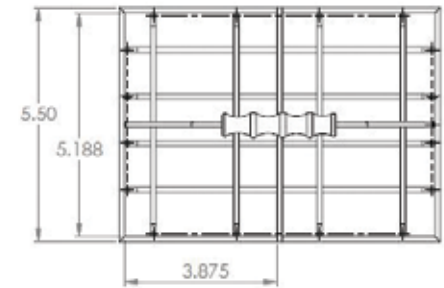
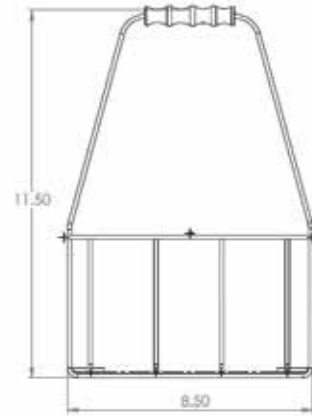
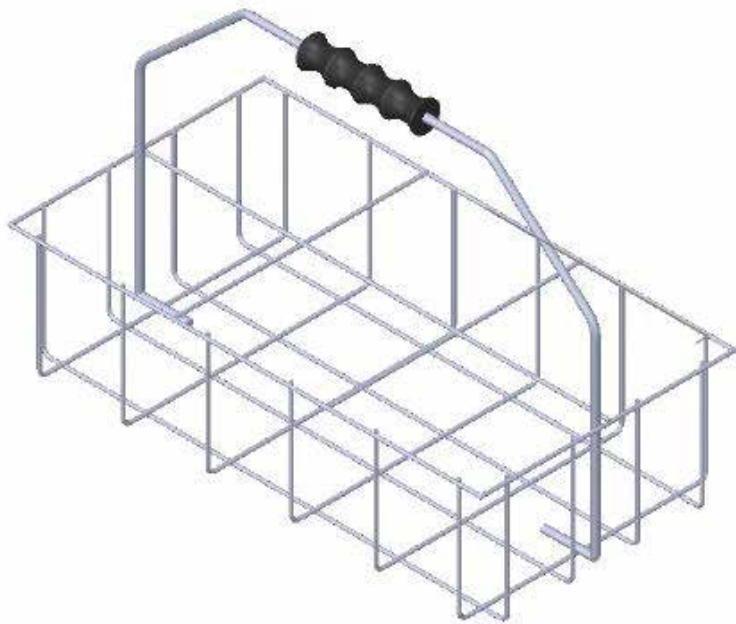

2 CELL HALF GALLON

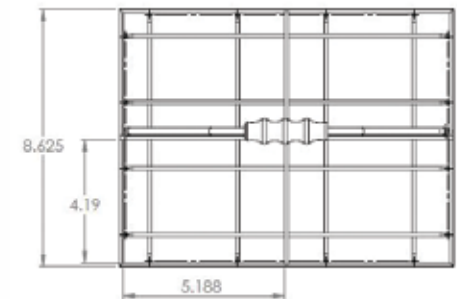
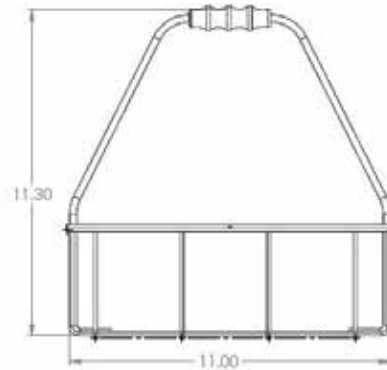

4 CELL HALF GALLON

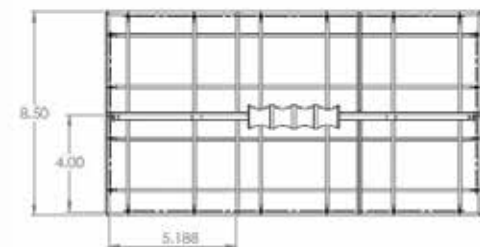
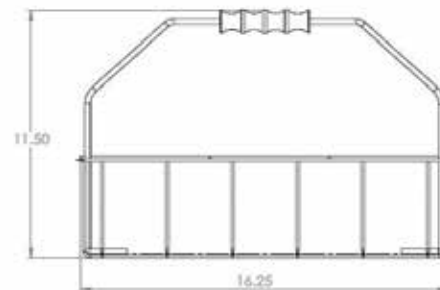

6 CELL HALF GALLON

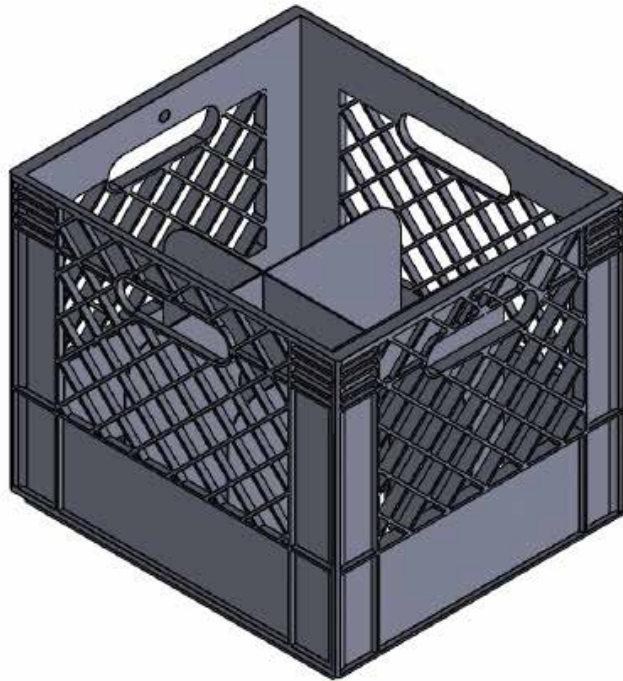

6 CELL HALF GALLON

6 CELL HALF GALLON PLASTIC DIVIDED CASE ◀

6 CELL HALF GALLON GENERAL INFORMATION:

Standard In Stock Case Color: Blue
 Case Weight: 2.8 lbs
 Pallet Weight: 304 lbs
 Case Dimensions: 13"W x 12"L x 11"H
 Pallet Dimensions: 40"W x 48"L x 91"H
 *Minimum 1 pallet
 *26 Pallet Maximum

CASE PRINTING / HOT STAMPING:

Minimum Order Qty.: 1,248 pc
 Max. Print Surface: 1.75"H x 3.75"W
 Delivery: 4-6 Weeks
 Green, Red or Black Cases Colors Available
 with Minimum Order of 1,248 pc

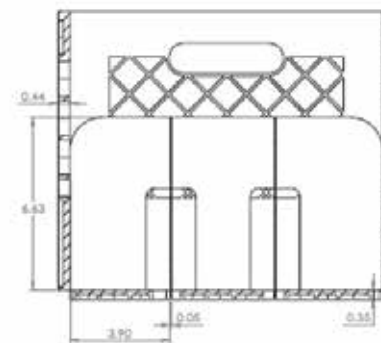
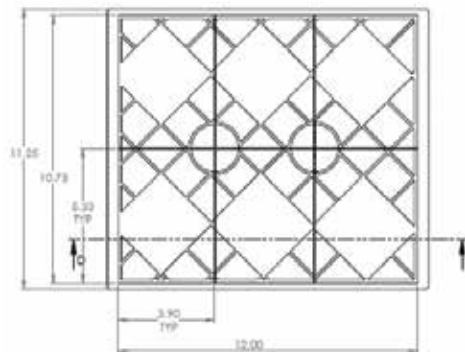
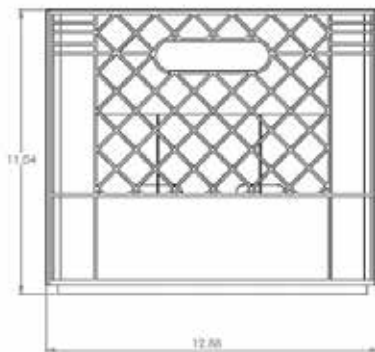

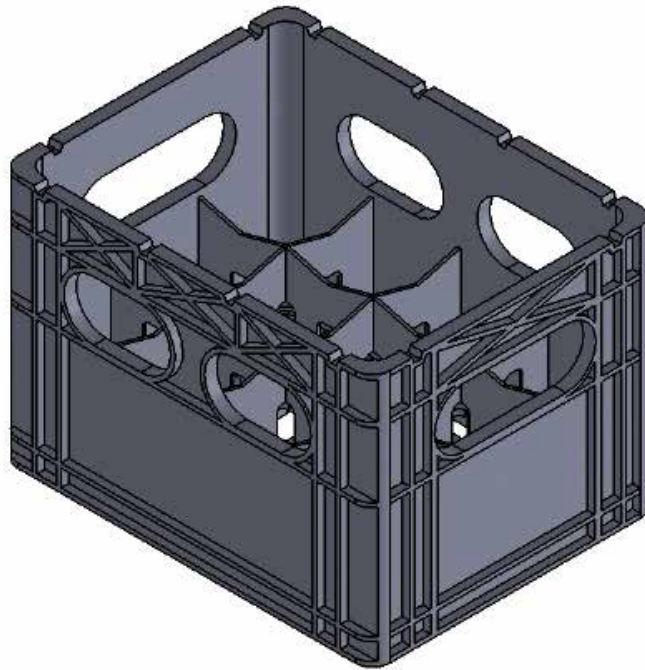

12 CELL SQUARE QUART PLASTIC DIVIDED CASE ◀

12 CELL SQUARE QUART GENERAL INFORMATION:

Standard In Stock Case Color: Blue
 Case Weight: 4.6 lbs
 Pallet Weight: 357 lbs
 Case Dimensions: 11.5"W x 15"L x 11"H
 Pallet Dimensions: 40"W x 48"L x 78"H
 *Minimum 1 pallet
 *26 Pallet Maximum

12 CELL SQUARE QUART

CASE PRINTING / HOT STAMPING:

Minimum Order Qty.: 1,820 pc
 Max. Print Surface: 3"H x 5"W
 Delivery: 4-6 Weeks
 Green & Red Cases Colors Available
 with Minimum Order of 1,820 pc

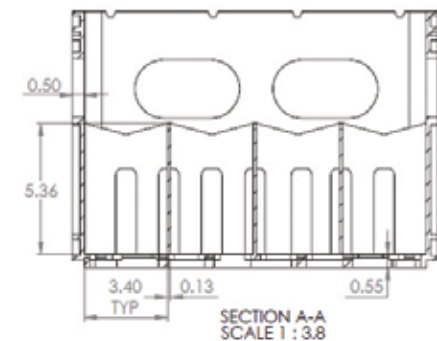
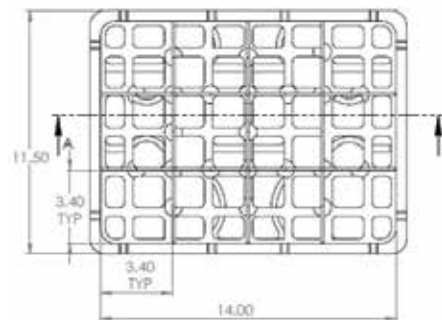
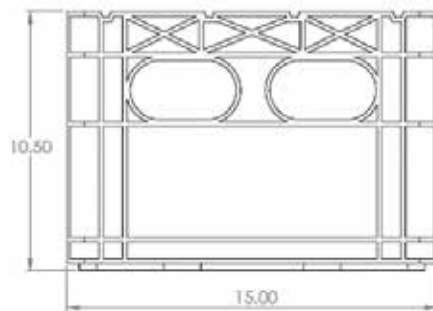





**FOOD SERVICE
PACKAGING ◀**



4 OZ / 118 ML CUP

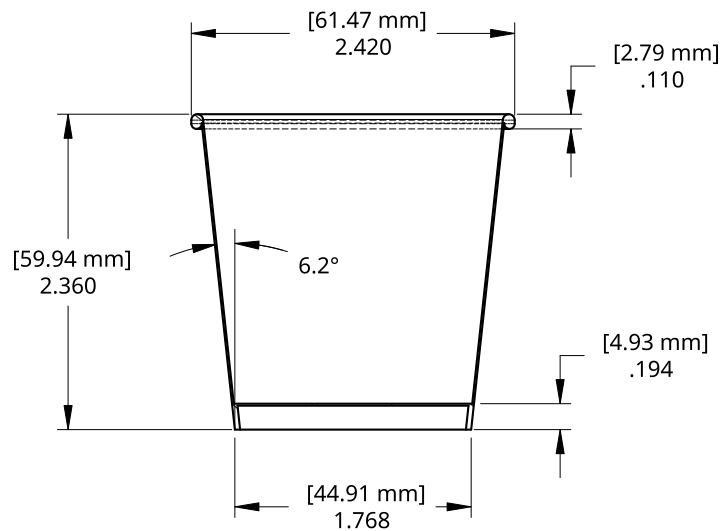

4 OZ PAPER HOT CUP ◀

CUP PROPERTIES:

Maximum Fill Volume: 4.02 fl. oz / 119 ml
 Practical Volume: 4 oz / 118 ml
 Stack Height: 11.9" / 50 Cups
 Sidewall Material: 14 PT, Polycoated 1 Side, 3/4 mil

PACKAGING CONFIGURATIONS:

4 oz Cups:

Qty Per Case: 1,000
 Qty Per Skid: 70,000
 Lbs Per Case: 9.5
 Qty Per Layer: 14
 Layers Per Skid: 5
 Carton Per Skid: 70
 Lbs Per Skid: 700
 Box Dimensions: 13" x 10" x 13"
 Pallet Dimensions: 40" x 48" x 70"

STOCK CUP DESIGN:



Euro



6 OZ / 177 ML CUP

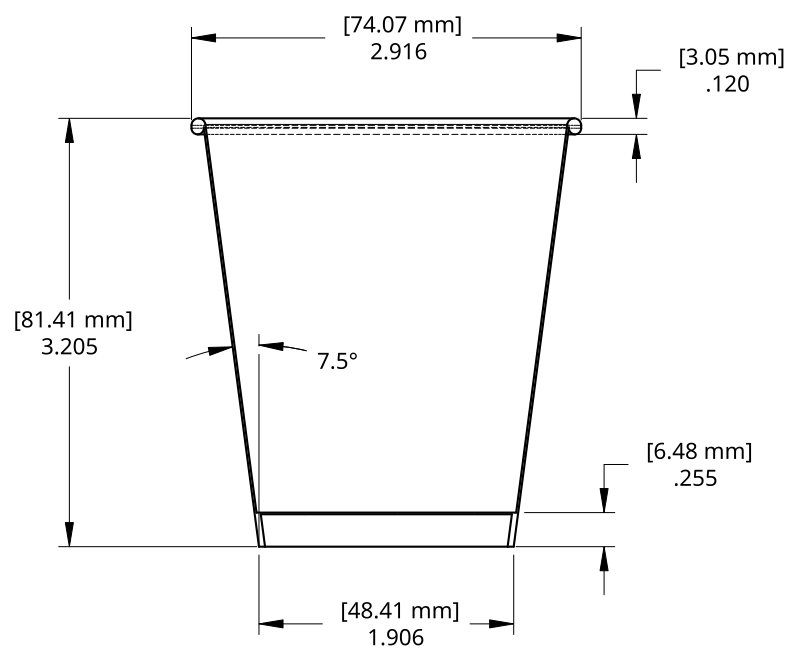

6 OZ PAPER HOT CUP ◀

CUP PROPERTIES:

Maximum Fill Volume: 7.3 fl. oz / 216 ml
 Practical Volume: 6 oz / 177 ml
 Stack Height: 13.9" / 50 Cups
 CaliPer: 15 PT, Polycoated 1 Side, 3/4 mil

PACKAGING CONFIGURATIONS:

6 oz Cups:

Qty Per Case: 1,000
 Qty Per Skid: 60,000
 Lbs Per Case: 15.2
 Qty Per Layer: 12
 Layers Per Skid: 5
 Carton Per Skid: 60
 Lbs Per Skid: 947
 Box Dimensions: 15" x 12" x 17"
 Pallet Dimensions: 40" x 48" x 90"



8 OZ / 237 ML CUP

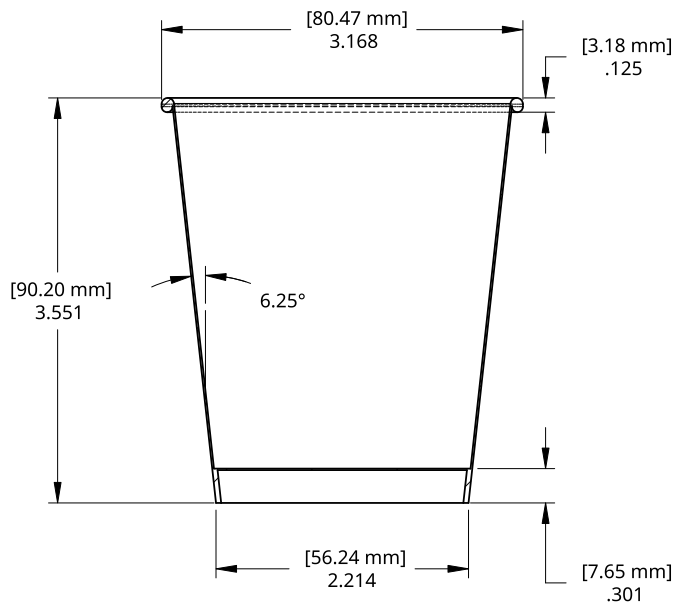

8 OZ PAPER HOT CUP ◀

CUP PROPERTIES:

Maximum Fill Volume: 9.7 oz / 286 ml
 Practical Volume: 8 oz / 237 ml
 Stack Height: 18.3" / 50 Cups
 Sidewall Material: 15 PT, Polycoated 1 Side, 3/4 mil

PACKAGING CONFIGURATIONS:

8 oz Cups:

Qty Per Case: 1,000
 Qty Per Skid: 36,000
 Lbs Per Case: 20.5
 Qty Per Layer: 9
 Layers Per Skid: 4
 Carton Per Skid: 36
 Lbs Per Skid: 773
 Box Dimensions: 17" x 13" x 19"
 Pallet Dimensions: 48" x 40" x 82"

STOCK CUP DESIGNS:





8 OZ / 237 ML CUP

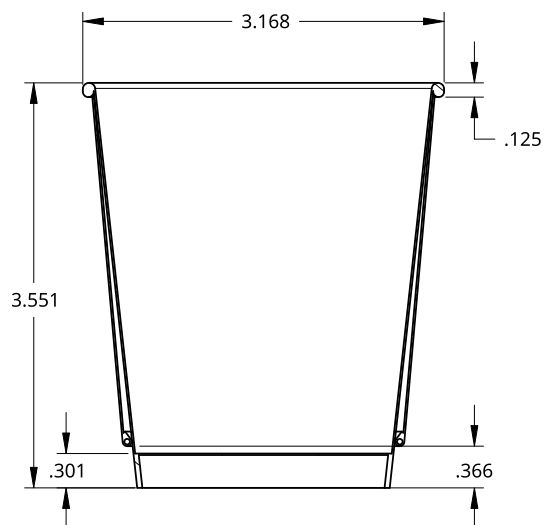

8 OZ DOUBLE WALL THERMAL HOT CUP ◀

CUP PROPERTIES:

Maximum Fill Volume: 9.66 oz / 286 ml
 Practical Volume: 8 oz / 237 ml
 Stack Height: 18.3" / 25 Cups
 Sidewall Material: 15 PT, Polycoated 1 Side, 3/4 mil

PACKAGING CONFIGURATIONS:

8 oz Cups:

Qty Per Case: 500
 Qty Per Skid: 15,000
 Lbs Per Case: 20
 Qty Per Layer: 5
 Layers Per Skid: 6
 Carton Per Skid: 30
 Lbs Per Skid: 635
 Box Dimensions: 17" x 14" x 24"
 Pallet Dimensions: 24" x 16" x 13"



10 OZ / 296 ML CUP

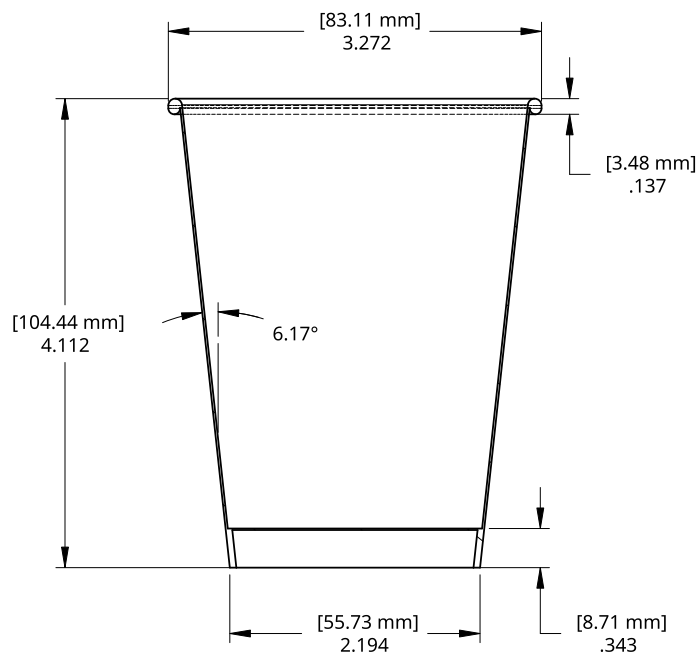

10 OZ TALL PAPER HOT CUP ◀

CUP PROPERTIES:

Maximum Fill Volume: 11.5 oz / 340 ml
 Practical Volume: 10 oz / 296 ml
 Stack Height: 20.9" / 50 Cups
 Sidewall Material: 17.5 PT, Polycoated 1 Side, 3/4 mil

PACKAGING CONFIGURATIONS:

10 oz Tall Cups:

Qty Per Case: 1,000
 Qty Per Skid: 36,000
 Lbs Per Case: 25
 Qty Per Layer: 9
 Layers Per Skid: 4
 Carton Per Skid: 36
 Lbs Per Skid: 935
 Box Dimensions: 17" x 13" x 22"
 Pallet Dimensions: 50" x 40" x 92"

STOCK CUP DESIGNS:



Olympic

Euro



10 OZ / 296 ML CUP

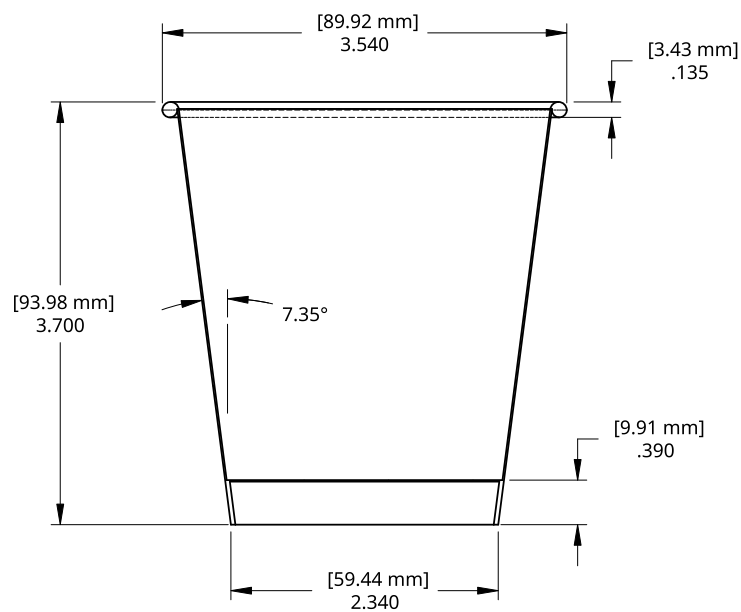

10 OZ SQUAT PAPER HOT CUP ◀

CUP PROPERTIES:

10 oz Squat Cups:

Maximum Fill Volume: 11.62 oz / 344 ml

Practical Volume: 10 oz / 296 ml

Stack Height: 22.8" / 50 Cups

Sidewall Material: 17.5 PT, Polycoated 1 Side, 3/4 mil

PACKAGING CONFIGURATIONS:

10 oz Squat Cups:

Qty Per Case: 1,000

Qty Per Skid: 24,000

Lbs Per Case: 26.5

Qty Per Layer: 6

Layer Per Skid: 4

Carton Per Skid: 24

Lbs Per Skid: 671

Box Dimensions: 18" x 15" x 24"

Pallet Dimensions: 48" x 40" x 101"

STOCK CUP DESIGNS:





12 OZ PAPER HOT CUP ◀

CUP PROPERTIES:

Maximum Fill Volume: 13.85 oz / 410 ml
 Practical Volume: 12 oz / 356 ml
 Stack Height: 23.4" / 50 Cups
 Sidewall Material: 17.5 PT, Polycoated 1 Side, 3/4 mil

PACKAGING CONFIGURATIONS:

12 oz Cups:

Qty Per Case: 1,000
 Qty Per Skid: 24,000
 Lbs Per Case: 31
 Qty Per Layer: 6
 Layers Per Skid: 4
 Carton Per Skid: 24
 Lbs Per Skid: 779
 Box Dimensions: 19" x 15" x 24"
 Pallet Dimensions: 40" x 48" x 100"

12 OZ / 356 ML CUP

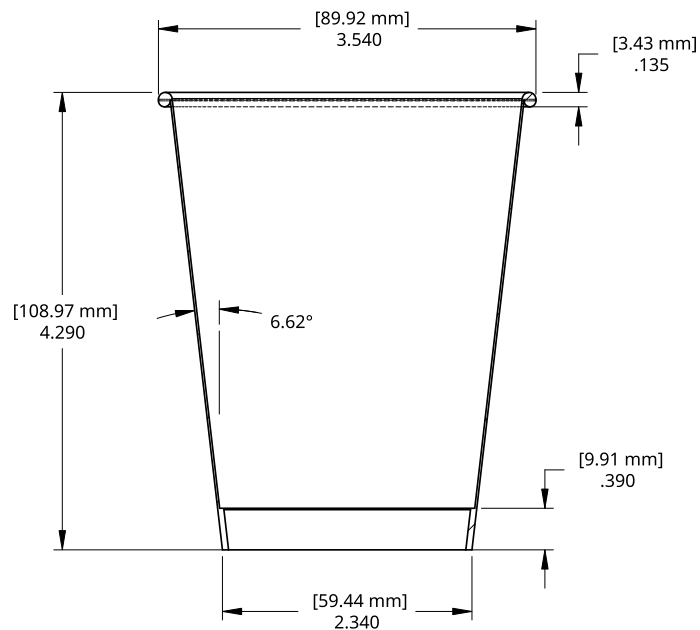

STOCK CUP DESIGNS:



Olympic

Euro

Milan

Topps





12 OZ / 355 ML CUP

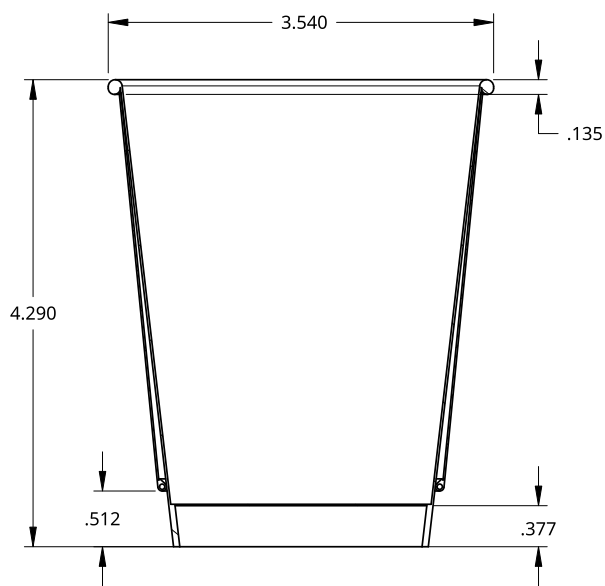

12 OZ DOUBLE WALL THERMAL HOT CUP ◀

CUP PROPERTIES:

Maximum Fill Volume: 13.85 oz / 410 ml
 Practical Volume: 12 oz / 355 ml
 Stack Height: 22.5" / 25 Cups
 Sidewall Material: 17.5 PT, Polycoated 1 Side, 3/4 mil
 Thermal Wrap: 15 PT, Polycoated 1 Side, 3/4 mil

PACKAGING CONFIGURATIONS:

12 oz Cups:

Qty Per Case: 500
 Qty Per Skid: 12,000
 Lbs Per Case: 30
 Qty Per Layer: 4
 Layers Per Skid: 6
 Carton Per Skid: 24
 Lbs Per Skid: 755
 Box Dimensions: 25" x 18" x 15"
 Pallet Dimensions: 48" x 40" x 93"



16 OZ / 473 ML CUP

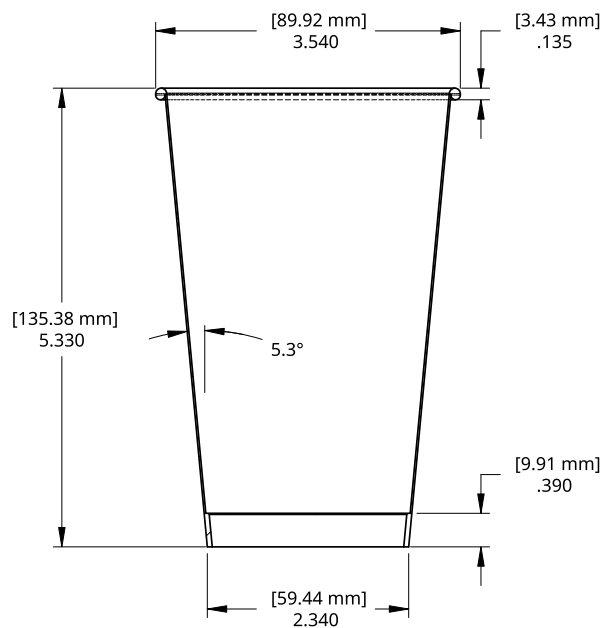

16 OZ PAPER HOT CUP ◀

CUP PROPERTIES:

Maximum Fill Volume: 17.4 oz / 525 ml
 Practical Volume: 16 oz / 473 ml
 Stack Height: 24.4"
 Sidewall Material: 17.5 PT, Polycoated 1 Side, 3/4 mil

PACKAGING CONFIGURATIONS:

16 oz Cups:

Qty Per Case: 1,000
 Qty Per Skid: 18,000
 Lbs Per Case: 35.6
 Qty Per Layer: 6
 Layers Per Skid: 3
 Cases Per Skid: 18
 Lbs Per Skid: 676
 Box Dimensions: 18" x 15" x 26"
 Pallet Dimensions: 49" X 40" X 94"

STOCK CUP DESIGNS:





16 OZ DOUBLE WALL THERMAL HOT CUP ◀

CUP PROPERTIES:

Maximum Fill Volume: 17.4 oz / 515 ml
 Practical Volume: 16 oz / 473 ml
 Stack Height: 22.5" / 20 Cups
 Sidewall Material: 17.5 PT, Polycoated 1 Side, 3/4 mil
 Thermal Wrap: 15 PT, Polycoated 1 Side, 3/4 mil

PACKAGING CONFIGURATIONS:

16 oz Cups:

Qty Per Case: 500
 Qty Per Skid: 10,000
 Lbs Per Case: 35
 Qty Per Layer: 4
 Layers Per Skid: 5
 Cases Per Skid: 20
 Lbs Per Skid: 735
 Box Dimensions: 18" x 25" x 18"
 Pallet Dimensions: 49" x 40" x 95"

16 OZ / 473 ML CUP

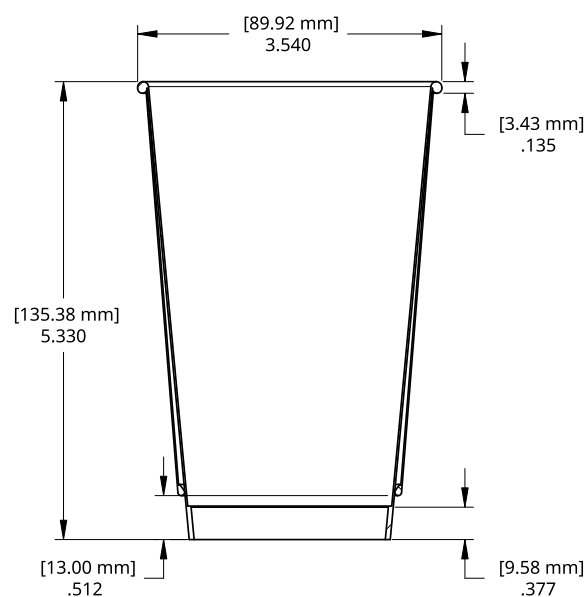



20 OZ / 591 ML CUP

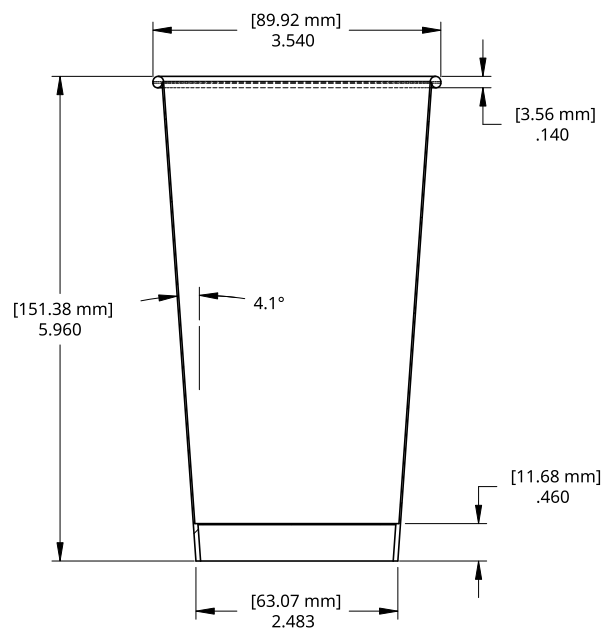

20 OZ PAPER HOT CUP ◀

CUP PROPERTIES:

Maximum Fill Volume: 20.25 oz / 599 ml
 Practical Volume: 20 oz / 591 ml
 Stack Height: 17" / 25 Cups
 Sidewall Material: 18 PT, Polycoated 1 Side, 3/4 mil

PACKAGING CONFIGURATIONS:

20 oz Cups:

Qty Per Case: 500
 Qty Per Skid: 15,000
 Lbs Per Case: 20
 Qty Per Layer: 6
 Layers Per Skid: 5
 Cases Per Skid: 30
 Lbs Per Skid: 635
 Box Dimensions: 18" x 15" x 18"
 Pallet Dimensions: 50" x 40" x 94"

STOCK CUP DESIGNS:





20 OZ / 599 ML CUP

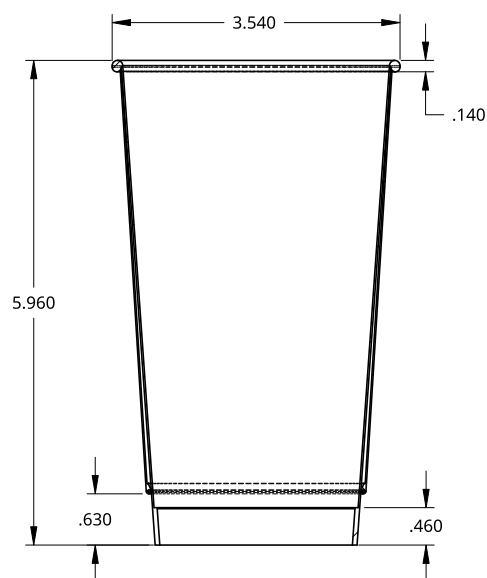

20 OZ DOUBLE WALL THERMAL HOT CUP ◀

CUP PROPERTIES:

Maximum Fill Volume: 20.25 oz / 599 ml

Practical Volume: 20 oz / 591 ml

Stack Height: 22" / 16 Cups

Sidewall Material: 17.5 PT, Polycoated 1 Side, 3/4 mil

Thermal Wrap: 13.5 PT, Polycoated 1 Side, 3/4 mil

PACKAGING CONFIGURATIONS:

20 oz Cups:

Qty Per Case: 400

Qty Per Skid: 8,000

Lbs Per Case: 26

Qty Per Layer: 4

Layers Per Skid: 5

Cases Per Skid: 20

Lbs Per Skid: 555

Box Dimensions: 18" x 18" x 25"

Pallet Dimensions: 40" x 48" x 98"



24 OZ PAPER HOT CUP ◀

CUP PROPERTIES:

Maximum Fill Volume: 23.6 oz / 698 ml
 Practical Volume: 23 oz / 680 ml
 Stack Height: 18.5" / 25 Cups
 Sidewall Material: 18 PT, Polycoated 1 Side, 3/4 mil
 Bottom Material: 13.5 PT, Polycoated 2 Sides, 1/2 x 3/4 mil

PACKAGING CONFIGURATIONS:

24 oz Cups:

500 Per Case – 15,000 Per Pallet
 6 Cases Per Layer
 5 Layers Per Pallet
 30 Cases Per Pallet
 20 lbs Per Case
 635 lbs Per Pallet
 Pallet Dimensions: 40" x 48" x 100"
 Box Size: 19" x 15" x 19"

24 OZ / 591 ML CUP

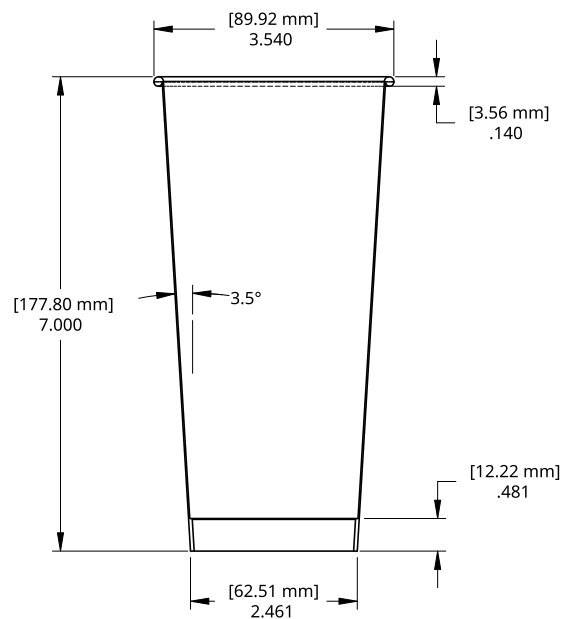



24 OZ DOUBLE WALL THERMAL HOT CUP ◀

CUP PROPERTIES:

Maximum Fill Volume: 20.3 oz / 599 ml
 Practical Volume: 20 oz / 591 ml
 Stack Height: 24" / 14 Cups
 Sidewall Material: 17.5 PT, Polycoated 1 Side, 3/4 mil
 Bottom Material: 14 PT, Polycoated 1 Side, 3/4 mil

PACKAGING CONFIGURATIONS:

24 oz Cups:

350 Per Case - 7,000 Per Pallet
 4 Cases Per Layer
 5 Layers Per Pallet
 28 Cases Per Pallet
 28 lbs Per Case
 595 lbs Per Pallet
 Pallet Dimensions: 50" x 40" x 98"
 Box Size: 25" x 18" x 18"

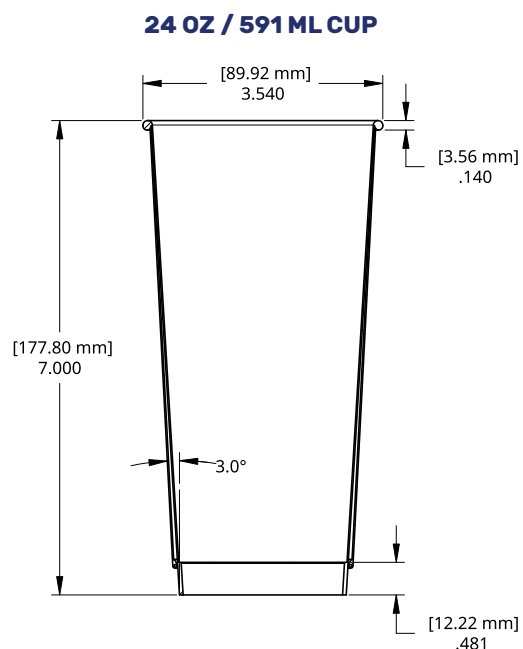

FOLDBACK LIDS ◀

PAPER HOT CUPS



4HL

4 OZ LID PROPERTIES:

Material Type: HIPS
(High Impact Polystyrene)

PACKAGING CONFIGURATIONS

4 oz Lids:

Qty Per carton: 1,000
Qty Per Skid: 96,000
Lbs Per carton: 4
Qty Per Layer: 24
Layer Per Skid: 4
Carton Per Skid: 96
Lbs Per Skid: 343
Box Dimensions: 14" x 11" x 11"
Skid Height: 83"

8OZ LID PROPERTIES:

Material Type: HIPS
(High Impact Polystyrene)

PACKAGING CONFIGURATIONS

8 oz Lids:

Qty Per carton: 1,000
Qty Per Skid: 70,000
Lbs Per carton: 6
Qty Per Layer: 14
Layer Per Skid: 5
Carton Per Skid: 70
Lbs Per Skid: 455
Box Dimensions: 17" x 7" x 19"
Skid Height: 98"

10 OZ TALL LID PROPERTIES:

Material Type: HIPS
(High Impact Polystyrene)

PACKAGING CONFIGURATIONS

10 oz Tall Lids:

Qty Per carton: 1,000
Qty Per Skid: 60,000
Lbs Per carton: 6
Qty Per Layer: 12
Layer Per Skid: 5
Carton Per Skid: 60
Lbs Per Skid: 395
Box Dimensions: 18" x 8" x 18"
Skid Height: 98"

10 OZ SQUAT, 12, 16, 20, 24 OZ LID PROPERTIES:

Material Type: HIPS
(High Impact Polystyrene)

PACKAGING CONFIGURATIONS

10 oz Squat, 12, 16, 20, 24 oz Lids:

Qty Per carton: 1,000
Qty Per Skid: 60,000
Lbs Per carton: 7
Qty Per Layer: 12
Layer Per Skid: 5
Carton Per Skid: 60
Lbs Per Skid: 455
Box Dimensions: 19" x 8" x 18"
Skid Height: 79"

DOME LIDS ◀

PAPER HOT CUPS



4HLD

4 OZ LID PROPERTIES:

Material Type: HIPS
(High Impact Polystyrene)

PACKAGING CONFIGURATIONS:

4 oz Lids:

Qty Per carton: 1,000
Qty Per Skid: 120,000
Lbs Per carton: 4
Qty Per Layer: 12
Layer Per Skid: 10
Carton Per Skid: 120
Lbs Per Skid: 515
Box Dimensions:
13" x 11" x 9"
Skid Height: 95"

6 OZ LID PROPERTIES:

Material Type: HIPS
(High Impact Polystyrene)

PACKAGING CONFIGURATIONS:

6 oz Lids:

Qty Per carton: 1,000
Qty Per Skid: 90,000
Lbs Per carton: 6
Qty Per Layer: 18
Layer Per Skid: 5
Carton Per Skid: 90
Lbs Per Skid: 575
Box Dimensions:
18" x 15" x 9"
Skid Height: 99"

10 OZ TALL LID PROPERTIES:

Material Type: HIPS
(High Impact Polystyrene)

PACKAGING CONFIGURATIONS:

10 oz Tall Lids:

Qty Per carton: 1,000
Qty Per Skid: 60,000
Lbs Per carton: 6
Qty Per Layer: 12
Layer Per Skid: 5
Carton Per Skid: 60
Lbs Per Skid: 395
Box Dimensions:
19" x 8" x 19"
Skid Height: 99"

FOLDBACK DOME LIDS ◀

PAPER HOT CUPS



16FBL

8 OZ LID PROPERTIES:

Material Type: HIPS
(High Impact Polystyrene)

PACKAGING CONFIGURATIONS:

8 oz Lids:

QTY Per Case: 1,000
Qty Per Skid: 70,000
Lbs Per carton: 6
Qty Per Layer: 14
Layers Per Skid: 5
Cartons Per Skid: 70
Lbs Per Skid: 470
Box Dimensions:
17.1" x 7.125" x 18.937"
Skid Height: 99.685"

10 OZ SQUAT LID PROPERTIES:

Material Type: HIPS
(High Impact Polystyrene)

PACKAGING CONFIGURATIONS:

10 oz Lids:

Qty Per Case: 1,000
Qty Per Skid: 60,000
Lbs Per carton: 7
Qty Per Layer: 12
Layer Per Skid: 5
Carton Per Skid: 60
Lbs Per Skid: 455
Box Dimensions:
19" x 7.75" x 19.25"
Skid Height: 101.25"

12, 16, 20, 24 OZ LID PROPERTIES:

Material Type: HIPS
(High Impact Polystyrene)

PACKAGING CONFIGURATIONS:

12, 16, 20, 24 oz Lids:

Qty Per Case: 1,000
Qty Per Skid: 60,000
Lbs Per carton: 7
Qty Per Layer: 12
Layer Per Skid: 5
Carton Per Skid: 60
Lbs Per Skid: 470
Box Dimensions:
19" x 7.75" x 19.25"
Skid Height: 101.25"



8 OZ / 237 ML CUP

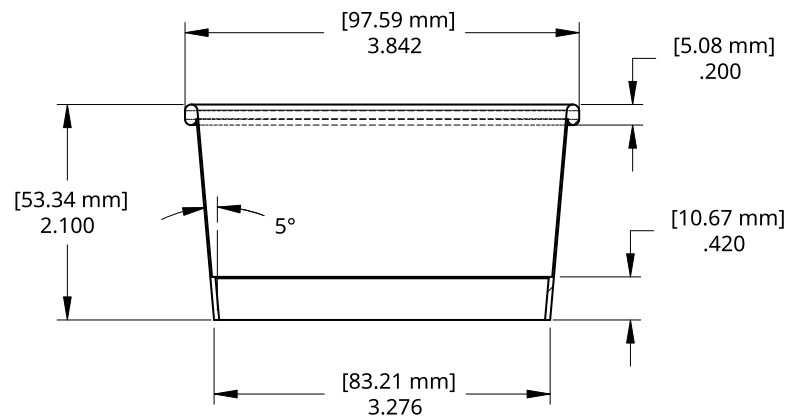

8 OZ PAPER FOOD CONTAINER CUP ◀

CUP PROPERTIES:

Maximum Fill Volume: 8.8 oz / 260 ml

Practical Volume: 8 oz / 237 ml

Stack Height: 22.7" / 50 Cups

Sidewall Material: 17.5 PT, Polycoated 2 Sides, 1/2 x 3/4 mil

PACKAGING CONFIGURATIONS:

8 oz Cups - 500 Pack:

Qty Per carton: 500

Qty Per Skid: 18,000

Lbs Per carton: 11.7

Qty Per Layer: 6

Layer Per Skid: 6

Carton Per Skid: 36

Lbs Per Skid: 456

Box Dimensions: 20" x 16" x 14"

Skid Height: 102"

STOCK CUP DESIGNS:



Great Day



8 OZ PAPER FOOD CONTAINER COMBO PACK ◀

CUP PROPERTIES:

Maximum Fill Volume: 8.8 oz / 260 ml

Practical Volume: 8 oz / 237 ml

Stack Height: 22.7" / 50 Cups

Sidewall Material: 17.5 PT, Polycoated 2 Sides, 1/2 x 3/4 mil

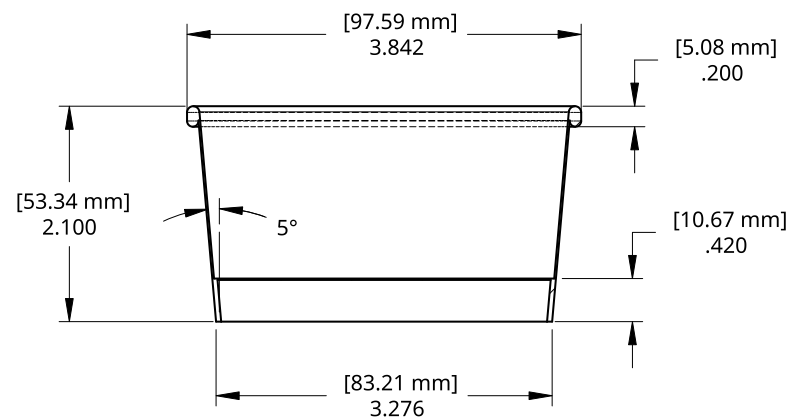

8 OZ / 237 ML CUP

PACKAGING CONFIGURATIONS:

KP Combo (using 1XP Lids):

Qty Per carton: 250

Qty Per Skid: 9,000

Lbs Per carton: 12.4

Qty Per Layer: 6

Layer Per Skid: 6

Carton Per Skid: 36

Lbs Per Skid: 481

Box Dimensions: 20" x 16" x 14"

Skid Height: 88"

KL Combo (using L16P Lids):

Qty Per carton: 250

Qty Per Skid: 10,000

Lbs Per carton: 9

Qty Per Layer: 8

Layer Per Skid: 5

Carton Per Skid: 40

Lbs Per Skid: 395

Box Dimensions: 20" x 12" x 16"

Skid Height: 85"

See Pg. 122 for Lid Properties



**PLASTIC LID (L16P)
PAPER VENTED LID (1XP)**



12.5 OZ / 370 ML CUP

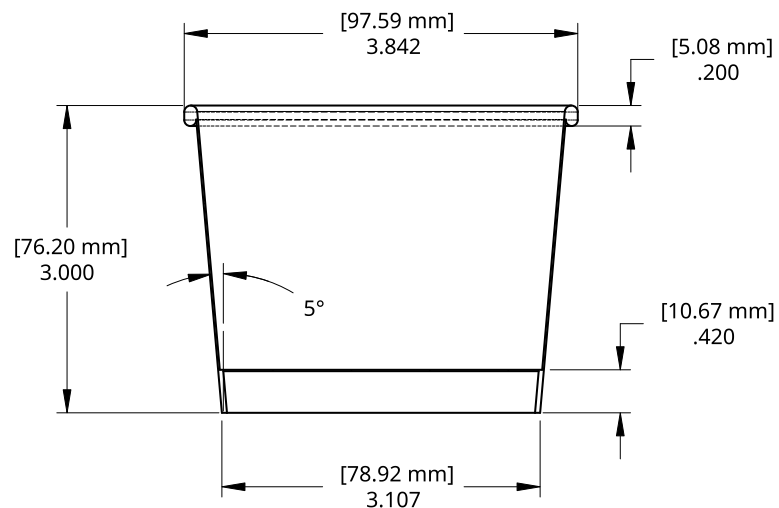

12 OZ PAPER FOOD CONTAINER CUP ◀

CUP PROPERTIES:

Maximum Fill Volume: 12.8 oz / 379 ml
 Practical Volume: 12.5 oz / 370 ml
 Stack Height: 23.6" / 50 Cups
 Sidewall Material: 17.5 PT, Polycoated 2 Sides, 1/2 x 3/4 mil

PACKAGING CONFIGURATIONS:

12 oz Cups - 500 Pack:

Qty Per carton: 500
 Qty Per Skid: 18,000
 Lbs Per carton: 16
 Qty Per Layer: 6
 Layer Per Skid: 6
 Carton Per Skid: 36
 Lbs Per Skid: 611
 Box Dimensions: 20" x 16" x 14"
 Skid Height: 90"

STOCK CUP DESIGNS:



Great Day



12 OZ PAPER FOOD CONTAINER COMBO PACK ◀

CUP PROPERTIES:

Maximum Fill Volume: 12.8 oz / 379 ml

Practical Volume: 12.5 oz / 370 ml

Stack Height: 23.6" / 50 Cups

Sidewall Material: 17.5 PT, Polycoated 2 Sides, 1/2 x 3/4 mil

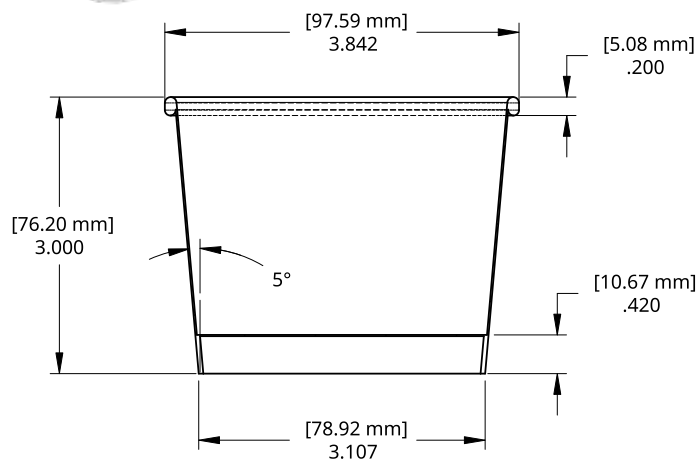

12 OZ / 355 ML CUP

PACKAGING CONFIGURATIONS:

KP Combo (using 1XP Lids):

Qty Per carton: 250

Qty Per Skid: 9,000

Lbs Per carton: 15

Qty Per Layer: 6

Layer Per Skid: 6

Carton Per Skid: 36

Lbs Per Skid: 575

Box Dimensions: 20" x 16" x 14"

Skid Height: 88"

KL Combo (using L16P Lids):

Qty Per carton: 250

Qty Per Skid: 10,000

Lbs Per carton: 11

Qty Per Layer: 8

Layer Per Skid: 5

Carton Per Skid: 40

Lbs Per Skid: 475

Box Dimensions: 20" x 12" x 16"

Skid Height: 85"

See Pg. 122 for Lid Properties



**PLASTIC LID (L16P)
PAPER VENTED LID (1XP)**



16 OZ / 473 ML CUP

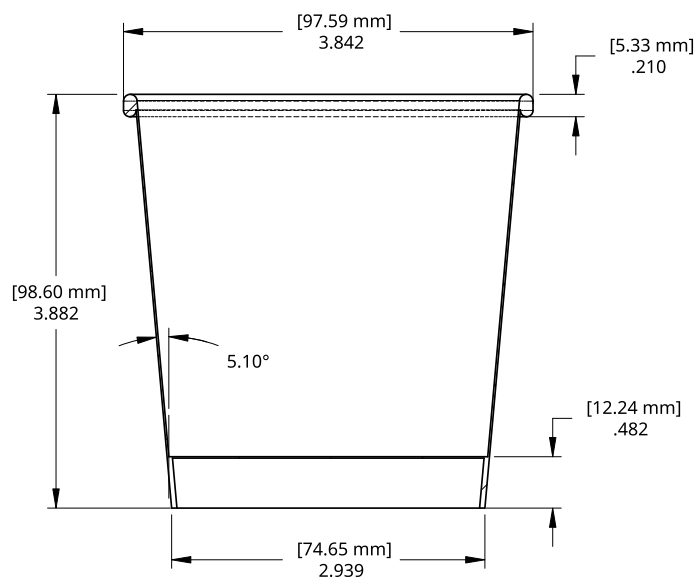

16 OZ PAPER FOOD CONTAINER CUP ◀

CUP PROPERTIES:

Maximum Fill Volume: 16.13 oz / 477 ml
 Practical Volume: 16 oz / 473 ml
 Stack Height: 27.7" / 50 Cups
 Sidewall Material: 17.5 PT, Polycoated 2 Sides, 1/2 x 3/4 mil

PACKAGING CONFIGURATIONS:

16 oz Cups - 500 Pack:

Qty Per carton: 500
 Qty Per Skid: 15,000
 Lbs Per carton: 18
 Qty Per Layer: 6
 Layer Per Skid: 5
 Carton Per Skid: 30
 Lbs Per Skid: 575
 Box Dimensions: 20" x 16" x 17"
 Skid Height: 90"

STOCK CUP DESIGNS:



Great Day

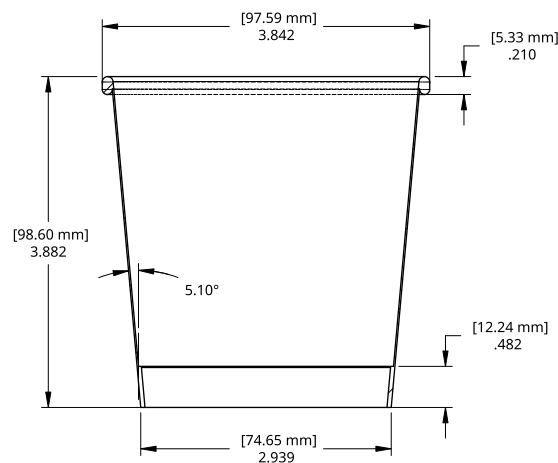

16 OZ / 473 ML CUP



**PLASTIC LID (L16P)
PAPER VENTED LID (1XP)**

16 OZ PAPER FOOD CONTAINER COMBO PACK ◀

CUP PROPERTIES:

Maximum Fill Volume: 16.13 oz / 477 ml

Practical Volume: 16 oz / 473 ml

Stack Height: 27.7" / 50 Cups

Sidewall Material: 17.5 PT, Polycoated 2 Sides, 1/2 x 3/4 mil

PACKAGING CONFIGURATIONS:

KP Combo (using 1XP Lids):

Qty Per carton: 250

Qty Per Skid: 7,500

Lbs Per carton: 16

Qty Per Layer: 6

Layer Per Skid: 5

Carton Per Skid: 30

Lbs Per Skid: 515

Box Dimensions: 20" x 16" x 16"

Skid Height: 85"

KL Combo (using L16P Lids):

Qty Per carton: 250

Qty Per Skid: 10,000

Lbs Per carton: 12

Qty Per Layer: 8

Layer Per Skid: 5

Carton Per Skid: 40

Lbs Per Skid: 515

Box Dimensions: 20" x 12" x 16"

Skid Height: 85"

See Pg. 122 for Lid Properties



32 OZ / 946 ML CUP

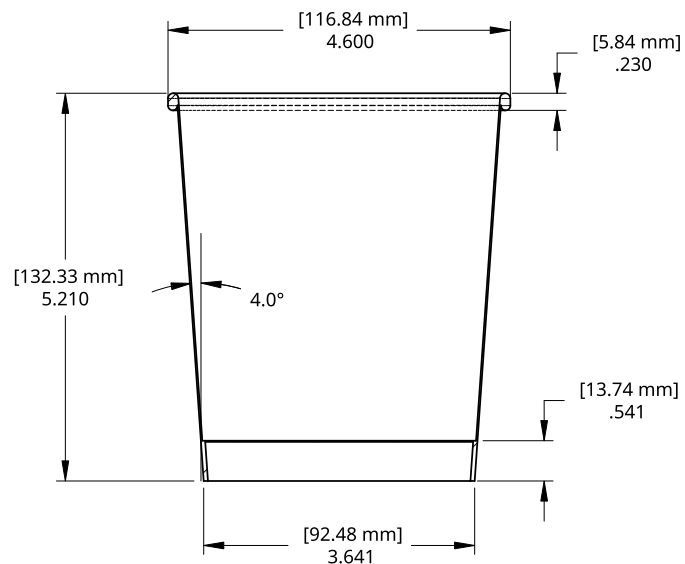

32 OZ PAPER FOOD CONTAINER CUP ◀

CUP PROPERTIES:

Maximum Fill Volume: 32.7 oz / 965 ml
 Practical Volume: 32 oz / 946 ml
 Stack Height: 18.7" / 25 Cups
 Sidewall Material: 18 PT, Polycoated 2 Sides, 1/2 x 3/4 mil

PACKAGING CONFIGURATIONS:

32 oz Cups:

Qty Per carton: 500
 Qty Per Skid: 16,000
 Lbs Per carton: 29
 Qty Per Layer: 4
 Layer Per Skid: 4
 Carton Per Skid: 16
 Lbs Per Skid: 499
 Box Dimensions: 23" x 19" x 20"
 Skid Height: 84"

STOCK CUP DESIGNS:



Great Day

VENTED FOOD CONTAINER LIDS ◀



PAPER VENTED LID (1XP)



PAPER VENTED LID (31XP)

8, 12, 16 OZ PAPER LID PROPERTIES:

Top Insert: Polycoated 1 Side, Paperboard Tube
Material: 3ply Paperboard
2 holes Per insert

PACKAGING CONFIGURATIONS:

8, 12, 16 oz Paper Lids:

Qty Per carton: 500
Qty Per Skid: 15,000
Lbs Per carton: 13
Qty Per Layer: 6
Layer Per Skid: 5
Carton Per Skid: 30
Lbs Per Skid: 461
Box Dimensions: 21" x 15" x 17"
Skid Height: 89"

32 OZ PAPER LID PROPERTIES:

Top Insert: Polycoated 1 Side, Paperboard Tube
Material: 3ply Paperboard
2 holes Per insert

PACKAGING CONFIGURATIONS:

32 oz Paper Lids:

Qty Per carton: 200
Qty Per Skid: 9,600
Lbs Per carton: 6
Qty Per Layer: 12
Layer Per Skid: 4
Carton Per Skid: 48
Lbs Per Skid: 328
Box Dimensions: 14" x 10" x 20"
Skid Height: 85"

PLASTIC FOOD CONTAINER LIDS ◀



PLASTIC LID (L16P)

8, 12, 16 OZ PLASTIC LID PROPERTIES:

Material Type: HIPS (High Impact Polystyrene)

PACKAGING CONFIGURATIONS:

8, 12, 16 oz Plastic Lids:

Qty Per carton: 500
Qty Per Skid: 25,000
Lbs Per carton: 6
Qty Per Layer: 10
Layer Per Skid: 5
Carton Per Skid: 50
Lbs Per Skid: 335
Box Dimensions: 20" x 9" x 16"
Skid Height: 101"

32 OZ PLASTIC LID PROPERTIES:

Material Type: HIPS (High Impact Polystyrene)

PACKAGING CONFIGURATIONS:

32 oz Plastic Lids:

Qty Per carton: 200
Qty Per Skid: 19,200
Lbs Per carton: 3.15
Qty Per Layer: 12
Layer Per Skid: 8
Carton Per Skid: 96
Lbs Per Skid: 305
Box Dimensions: 15" x 10" x 10"
Skid Height: 87"



STANPAC

PACKAGING PERFECTION FOR 75 YEARS | STANPACNET.COM | 905.957.3326